

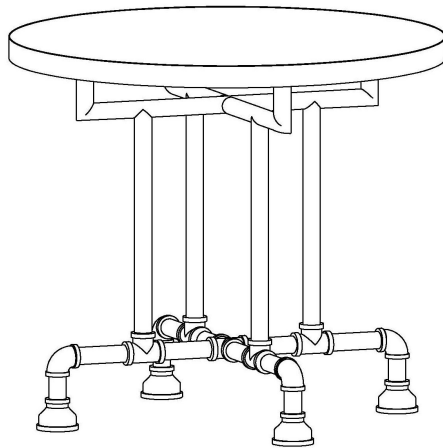

Assembly Instructions

Caution : You must read this before you proceed

End Table





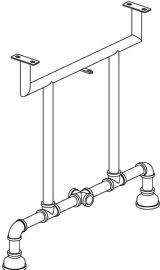

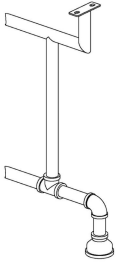
Parts List

Label	Picture	Description	QTY
A		Table Top	1
B		Metal Base	1

C		Side Tube	2
---	---	-----------	---

Hardware

Label	Picture	Description	QTY
①		Bolt (M6*16mm)	13
②		Washer	13
③		Spring Washer	13
④		Allen Wrench	1

Assembly Preparation

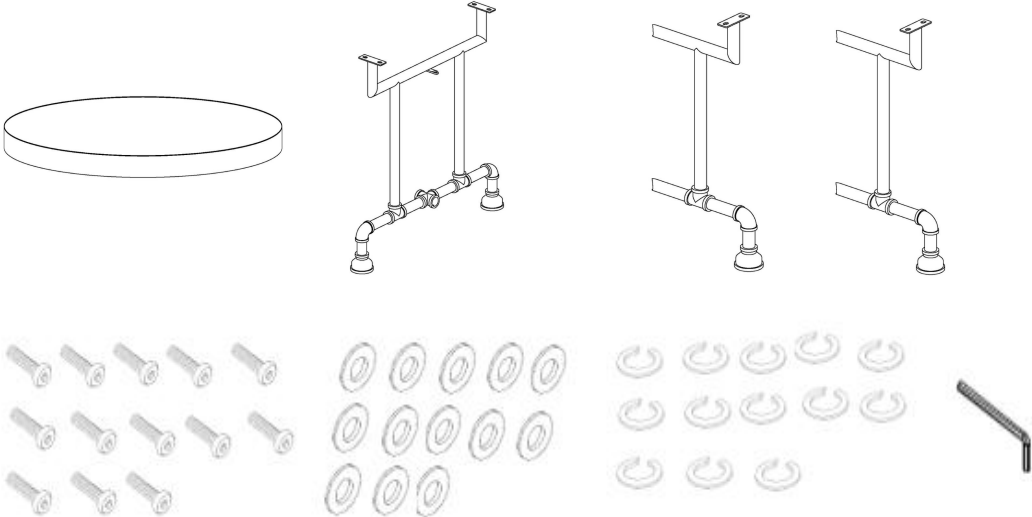
<p>Before Beginning Assembly:</p>				
--	--	--	--	--



- Read instructions, cover to cover-



- Have 2 adults on hand for assembly-



- Do not assemble on flooring or carpet-



- Assemble on a clean non-marring surface (packing foam)-



- Save all packaging until finished-

Assembly Steps

Overview

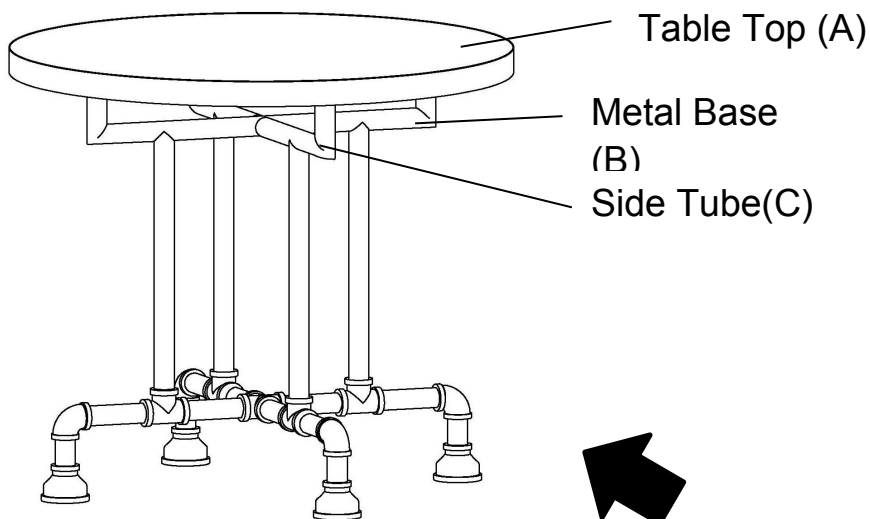

FRONT FACING

This End Table has multiple parts and may require up to 30 minutes to assemble. To give you an overview of the Coffee Table, the above picture is to help you put the various parts into perspective. Please read through the instructions below to familiarise yourself with the parts and steps before assembly.

Step 1

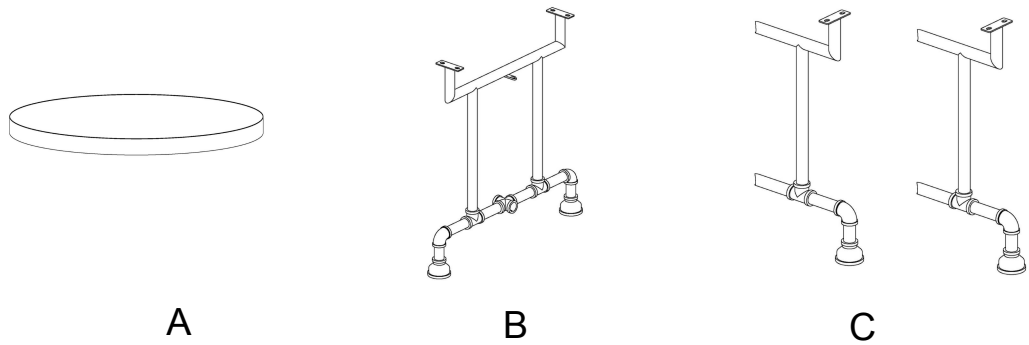

Place the Table Top(A), Metal Base(B) and Side Tube(C) on a clean, non-marring surface.

Step 2

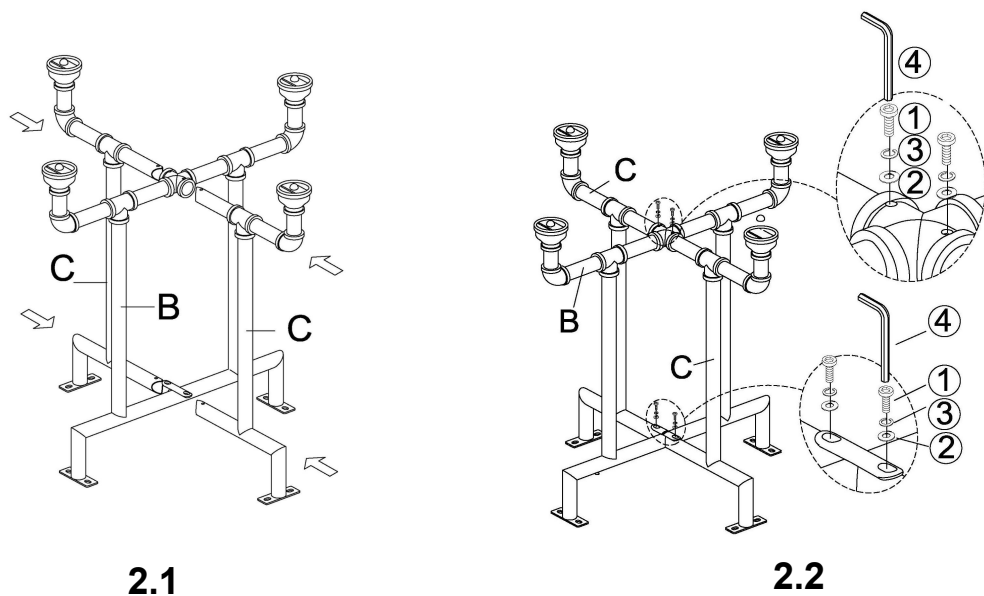

2.1) Insert the Side Tubes(C) into Metal Base(B) as pictured above.
2.2) Insert the Side Tubes(C) into Metal Base(B) using Bolts(1), Spring Washers(2), and Washers(3) with Allen Wrench(4).
Tighten the Bolts fully in a sequential manner.

Step 3

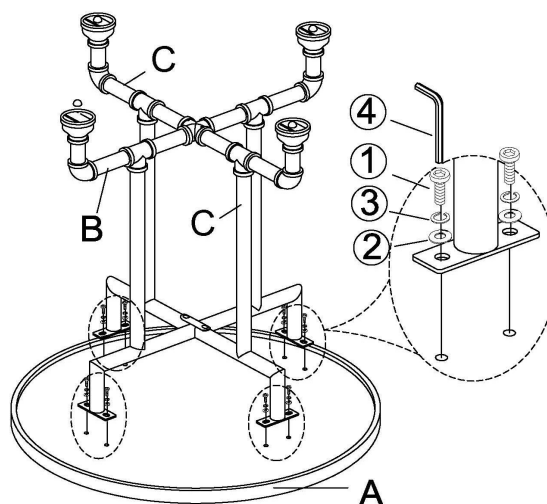

3.1) Place Table Top(A) facedown on a clean, non-marring surface. With assistance from an adult partner, carefully lift the assembled Side Tubes(B) up and align the assembled metal frame to the mount position in the table.

3.2) Attach Side Tubes(B) to Table Top(A) using Bolts(①) ,Spring Washers(②), and Washers(③) with Allen Wrench(④). Tighten the Bolts fully in a sequential manner.

Step 4

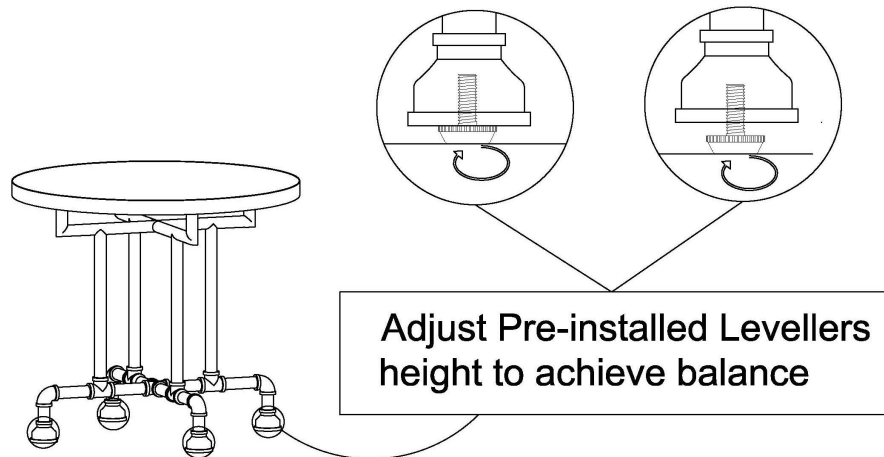





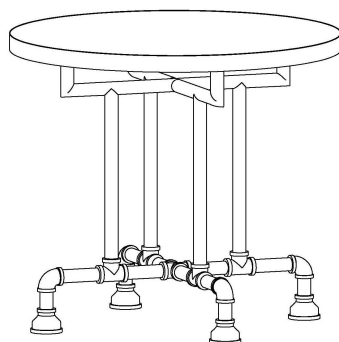



With assistance from an adult partner, stand the End Table up. Adjust the Pre-installed Levellers at the bottom of the Metal Base(B) and Side Tube(C) until the Coffee Table is level with the ground.

Step 5



Your End Table ready for use.
This End Table can only be used on a flat, level surface.

Care & Maintenance

-  ● Not for commercial use. For residential use only.
 -  ● Furniture may scratch floors. We recommend using furniture pads to protect your floors.
 -  ● Do not put hot items directly on furniture surface.
 -  ● Do not clean furniture with harsh cleansers or polish.
 -  ● Do not place furniture under direct sunlight.
 -  ● Do not place furniture near heating or cooling vents.
 -  ● Do not write on furniture without a padded barrier to protect the surface.
 -  ● Do not place furniture outside . For indoor use only.
 -  ● Stains may be removed with mild soap solution and damp cloth.
 -  ● Children should not climb or jump on the furniture.
-
-  ● Dust and pick-up spills using a clean, non-colored, lint-free cloth.