

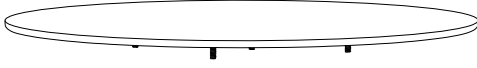

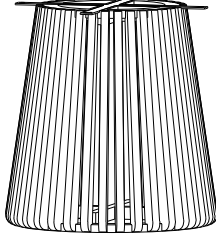

ASSEMBLY INSTRUCTIONS

Part List

ITEM CODE-281-016

Label	Picture	Description	Qty.
1.		TOP	1 Pc.
2.		BASE	1 Pc.

HARDWARE LIST :

Label	Picture	Description	Qty.
A		HEX NUT	4 Pcs.
B		WASHER	4 Pcs.
C		WRENCH	1 Pc.

STEP-1

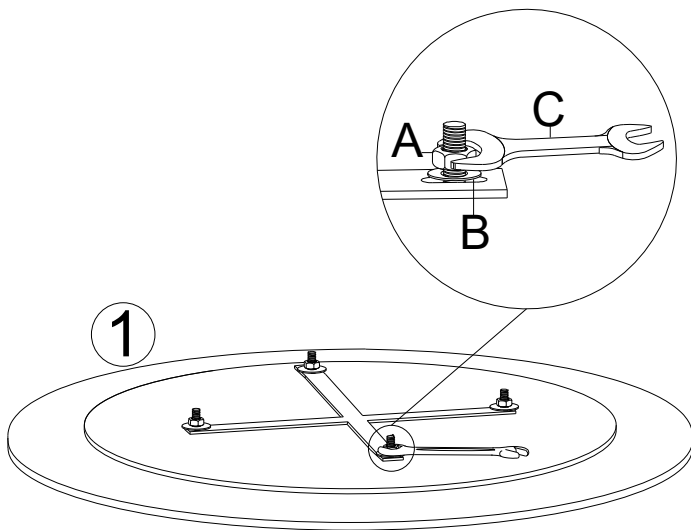

Remove the hex nut and washer, as shown in image view.

STEP-2

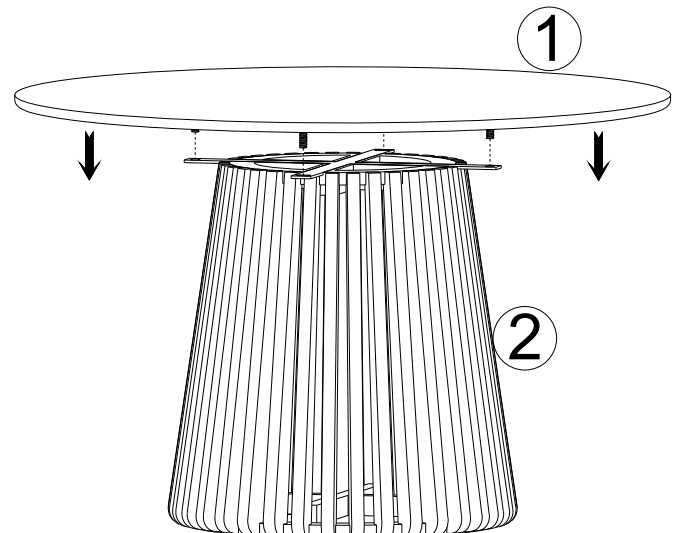

STEP-3

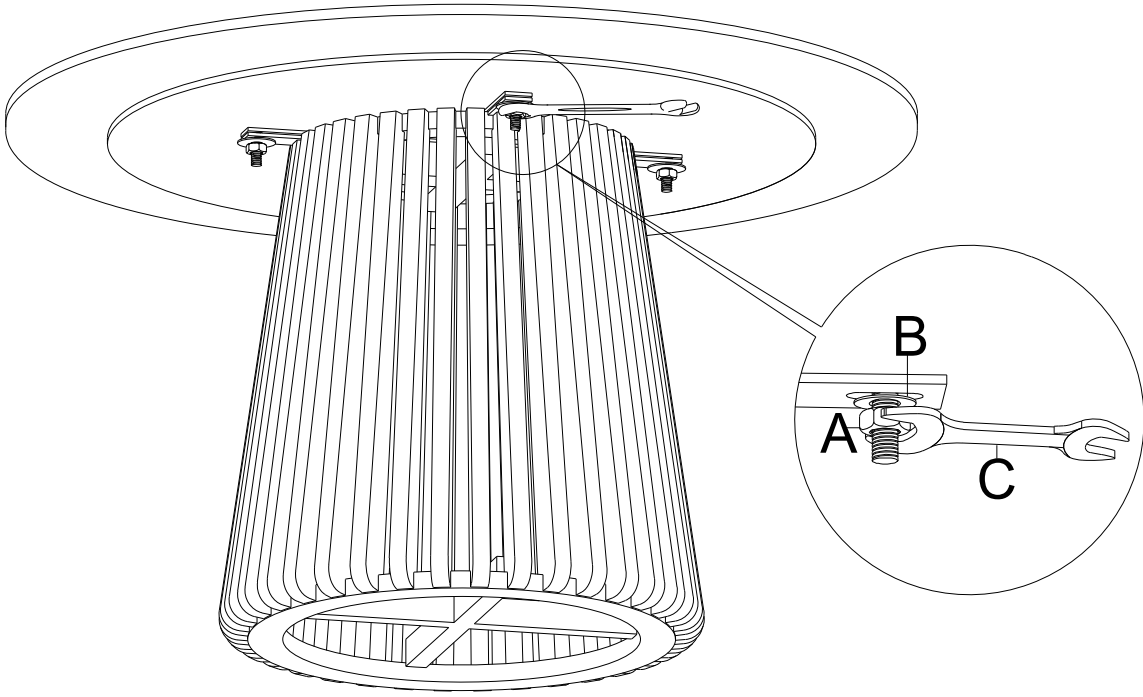

STEP-4

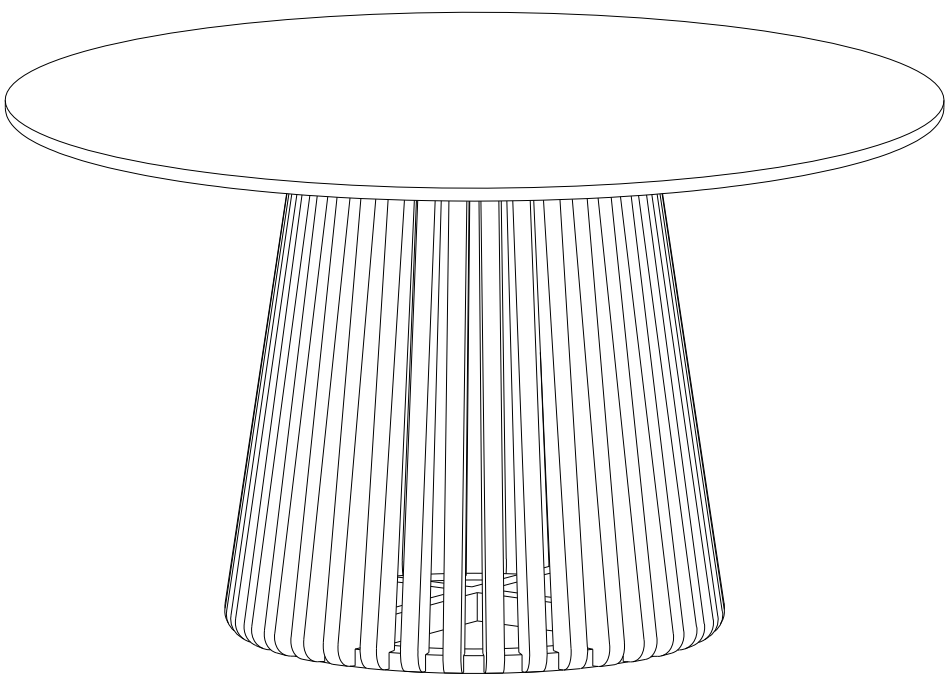

COMPLETELY ASSEMBLED