

30'

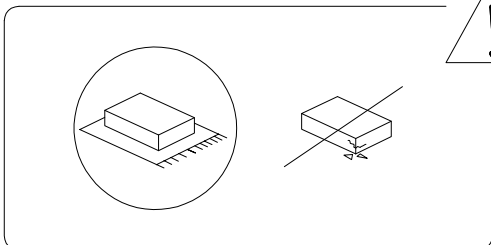

2

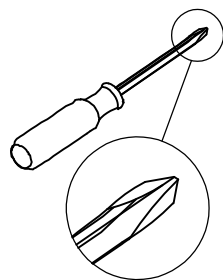
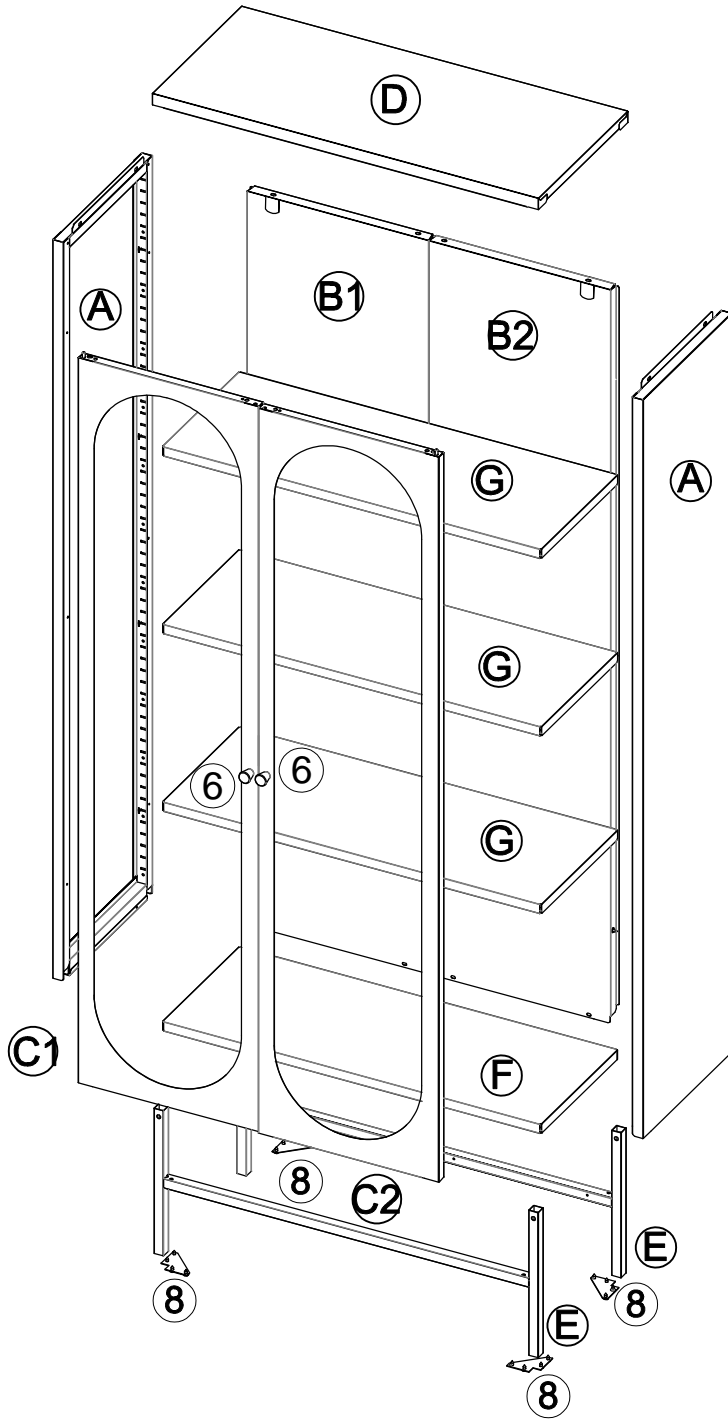

Hardware	Ctn No.	1
----------	---------	---

No.	Size	Qty
A	1618x350x24mm	2
B1	1590x380x23mm	1
B2	1590x384x23mm	1
C1	1571x373.5x20mm	1
C2	1571x373.5x20mm	1
D	801x351.5x38mm	1
E	370x797x20mm	2
F	796x301x25mm	1
G	796x300x20mm	3

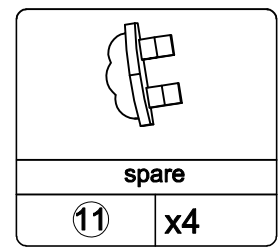
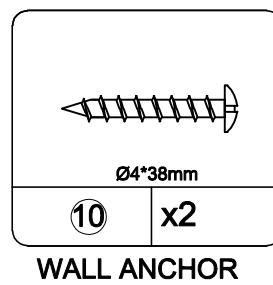
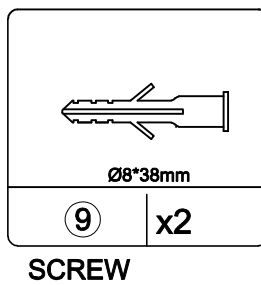
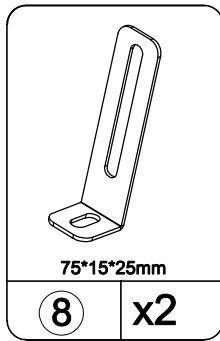
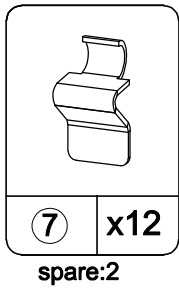
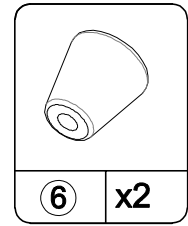
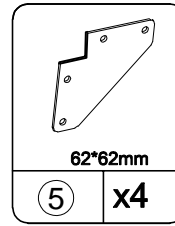
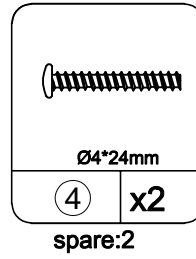
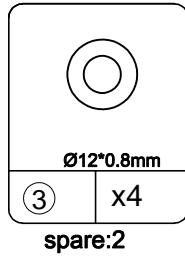
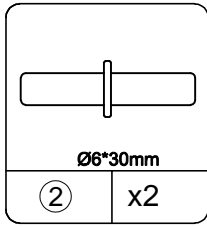
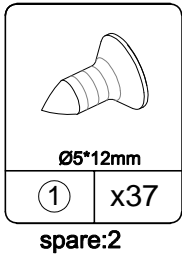

(1) - Attach (A) to (E) as below shown.

Make sure the holes are nearest to outside otherwise will affect door assembling.

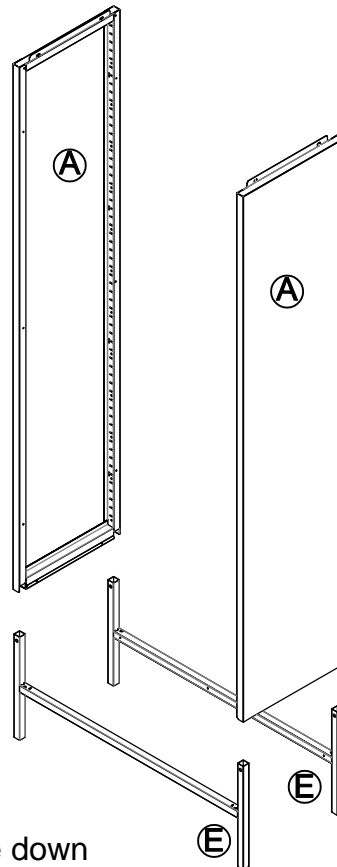
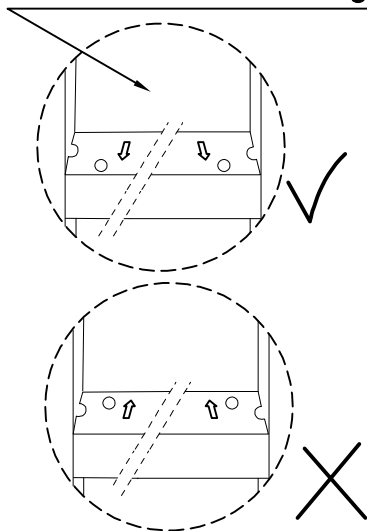

The plastic foot cover face down

(2) - Attach ⑤ to (A)&(E) as below shown.

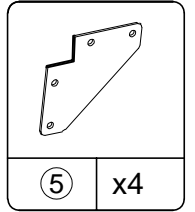
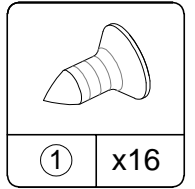
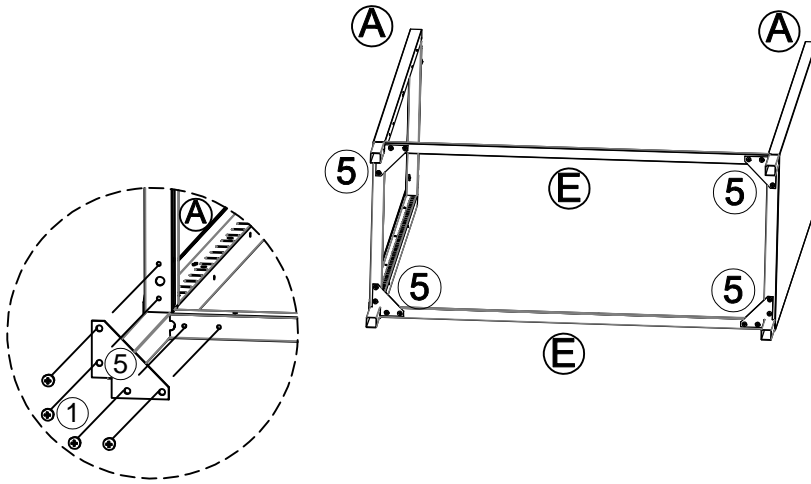

(3) - Attach (B1) & (B2) to (A) as below shown.

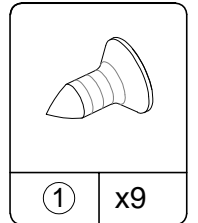
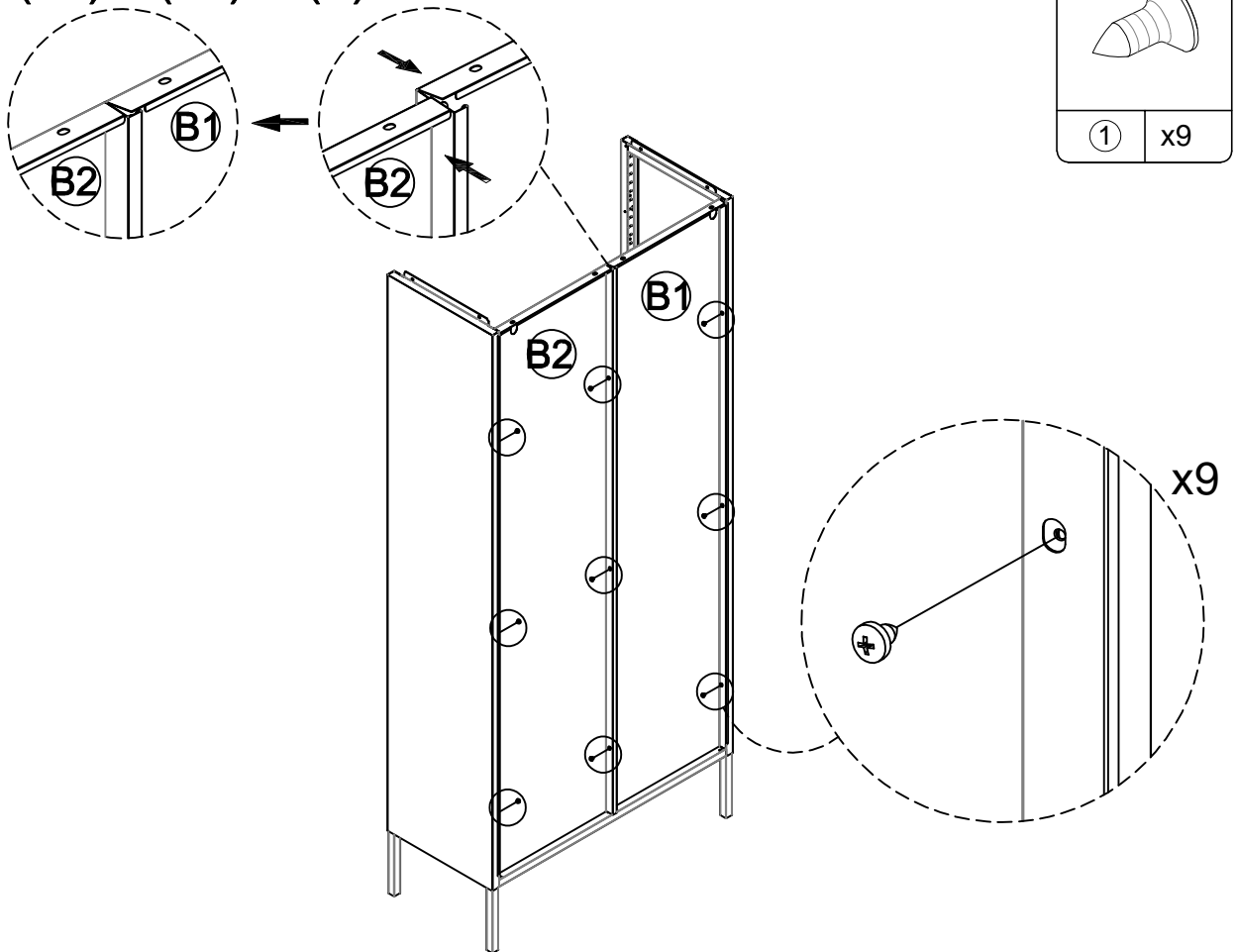

(4) - Attach (B) to (A) & (E) as below shown.

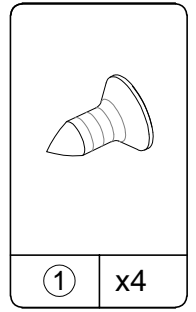
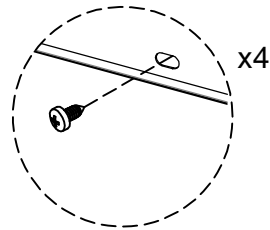
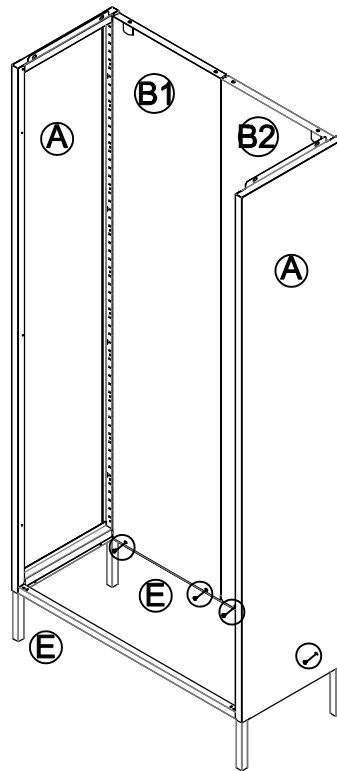

(5) - Attach (F) to (A) & (B) & (E) as below shown.

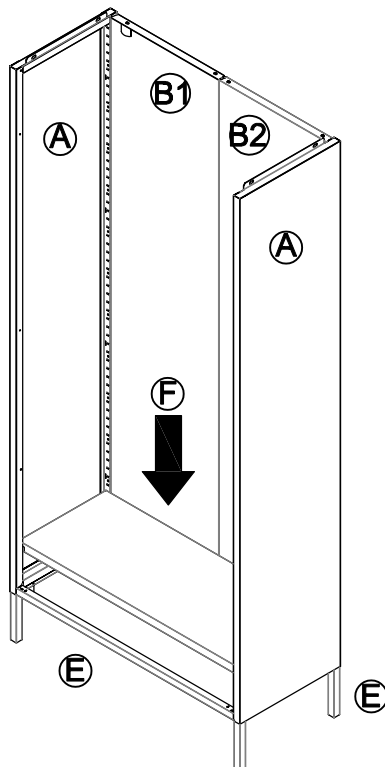

(6) - Attach (D) to (A) & (B) as below shown.

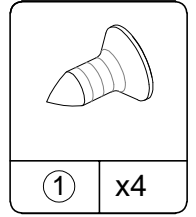
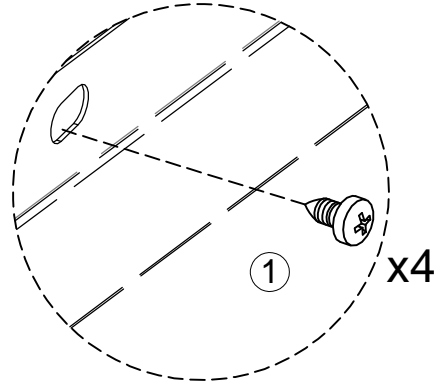
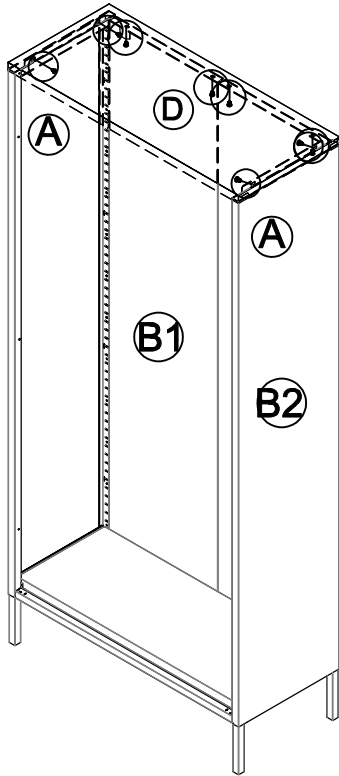

(7) - Attach (B) & (8) to (D) as below shown.

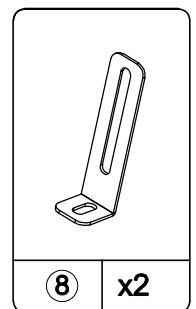
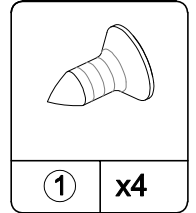
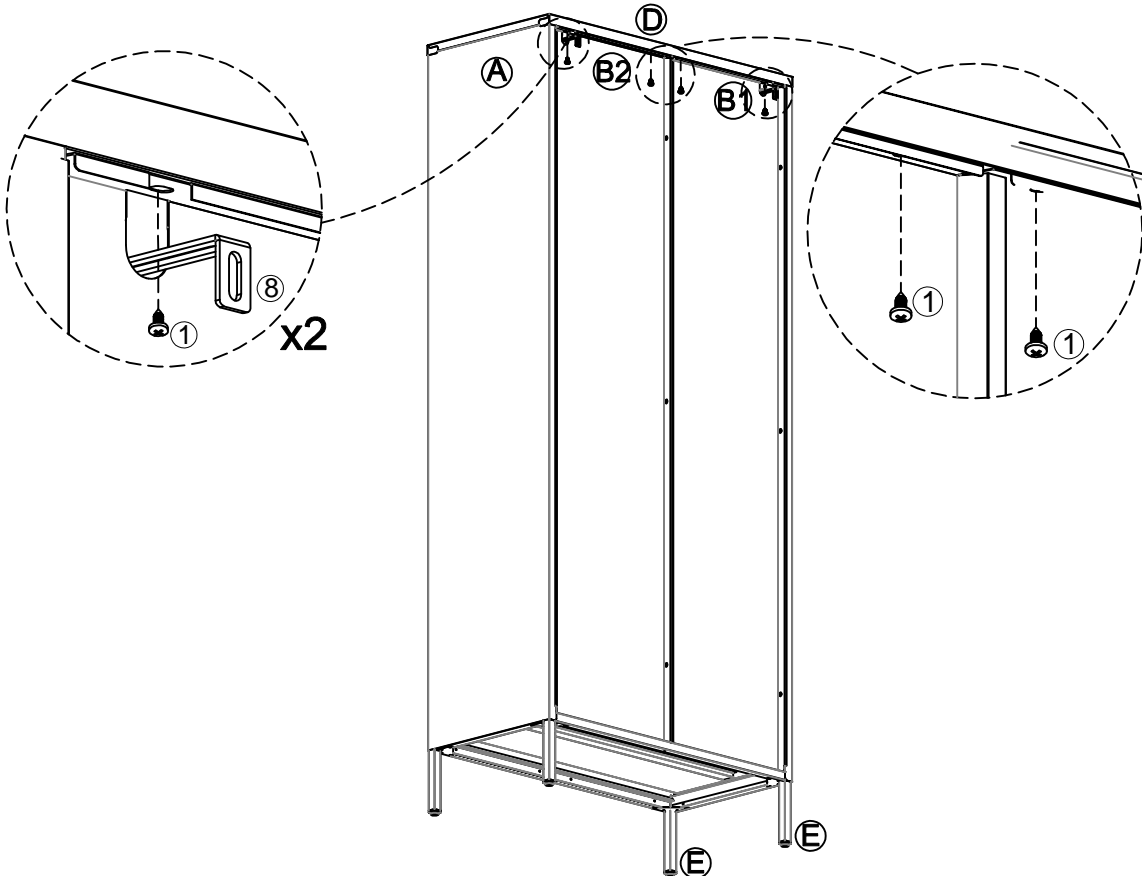

(8) - Attach (G) to pre-assembled unit as below shown.

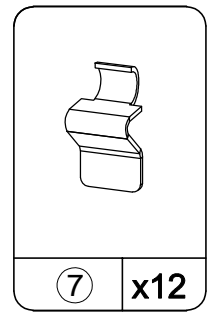
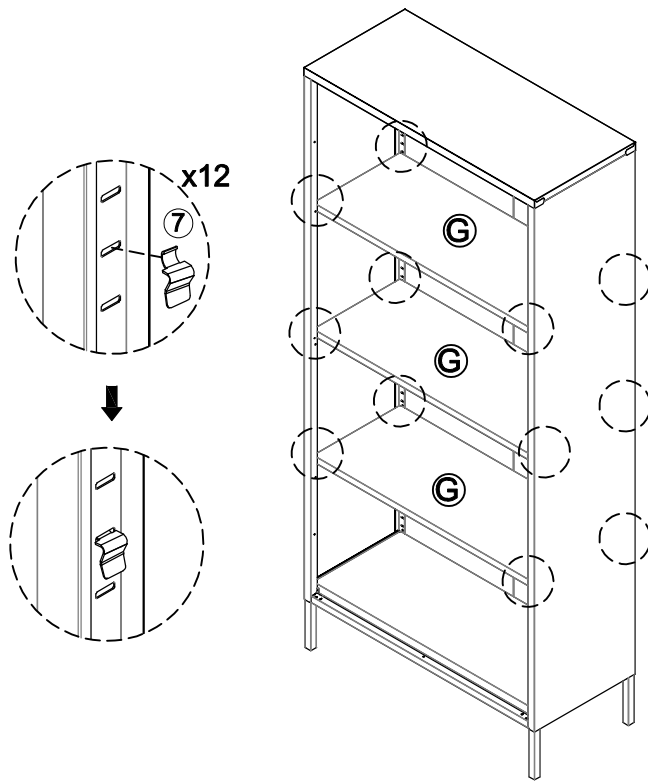

(9) - Attach (2) & (3) to pre-assembled unit as below shown.

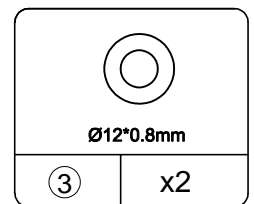
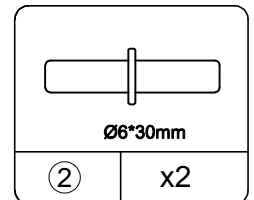
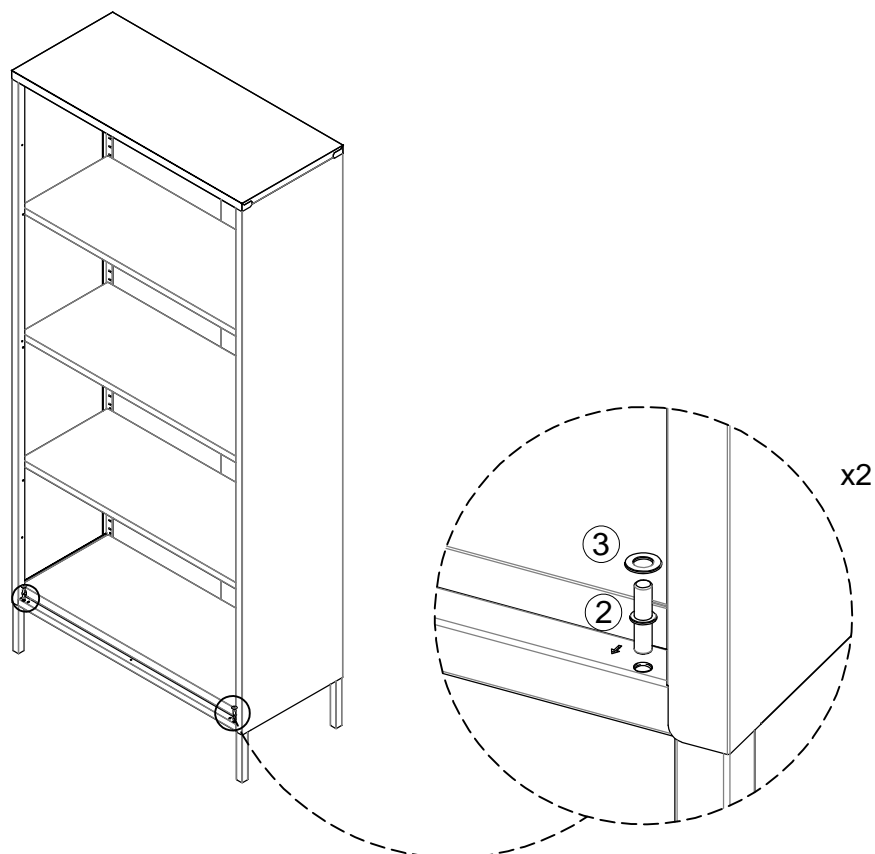

(10) - Attach (6) to (C) as below shown.

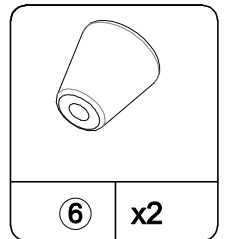
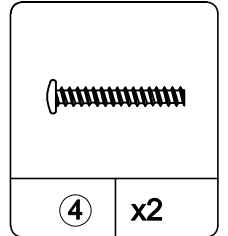
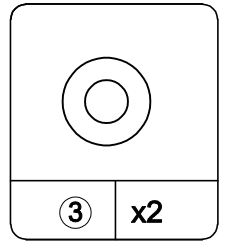
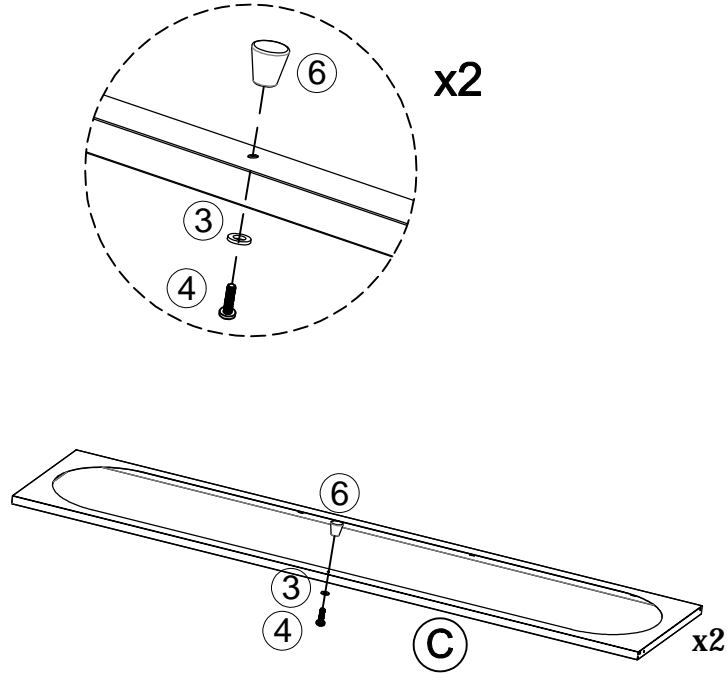

spare parts of glass buckle

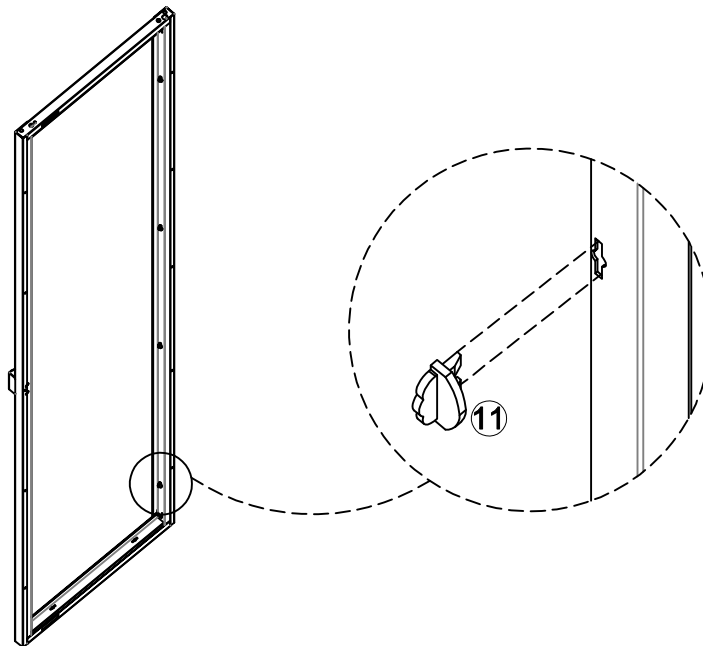

(11) - Attach (C) to pre-assembled unit as below shown.

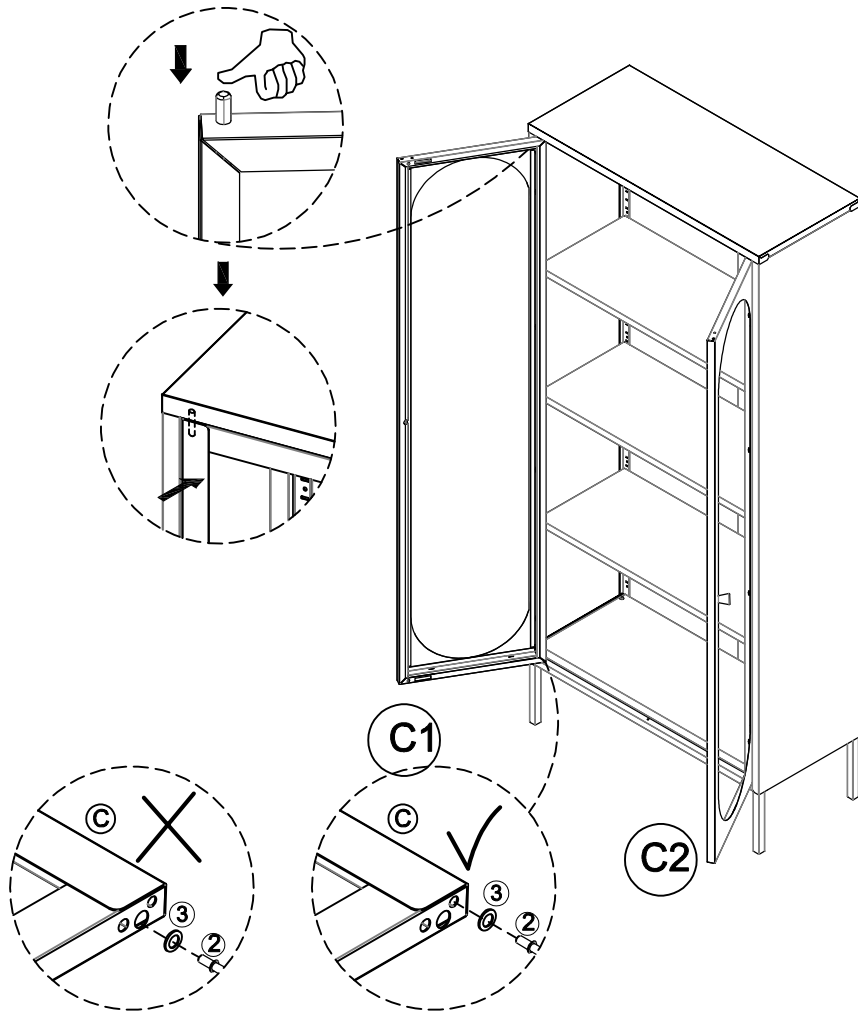

door pillar exchange process

WARNING

This step is just to switch the left door to the right door!

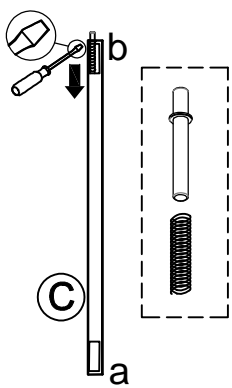

STEP 1

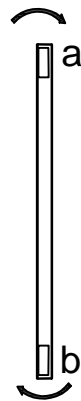

STEP 2

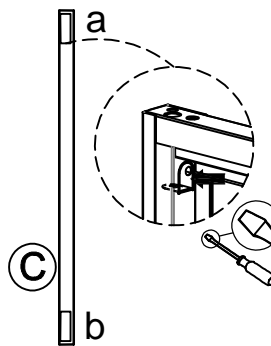

STEP 3

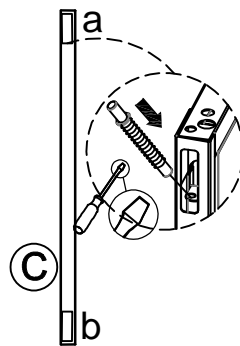

STEP 4

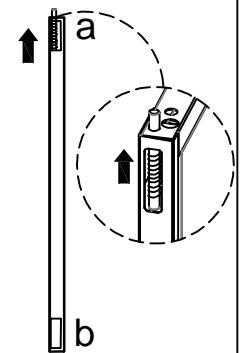

STEP 5

(12)

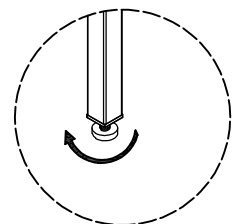
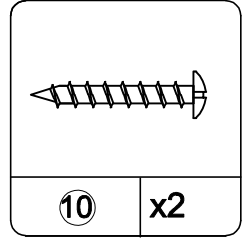
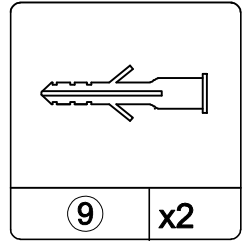
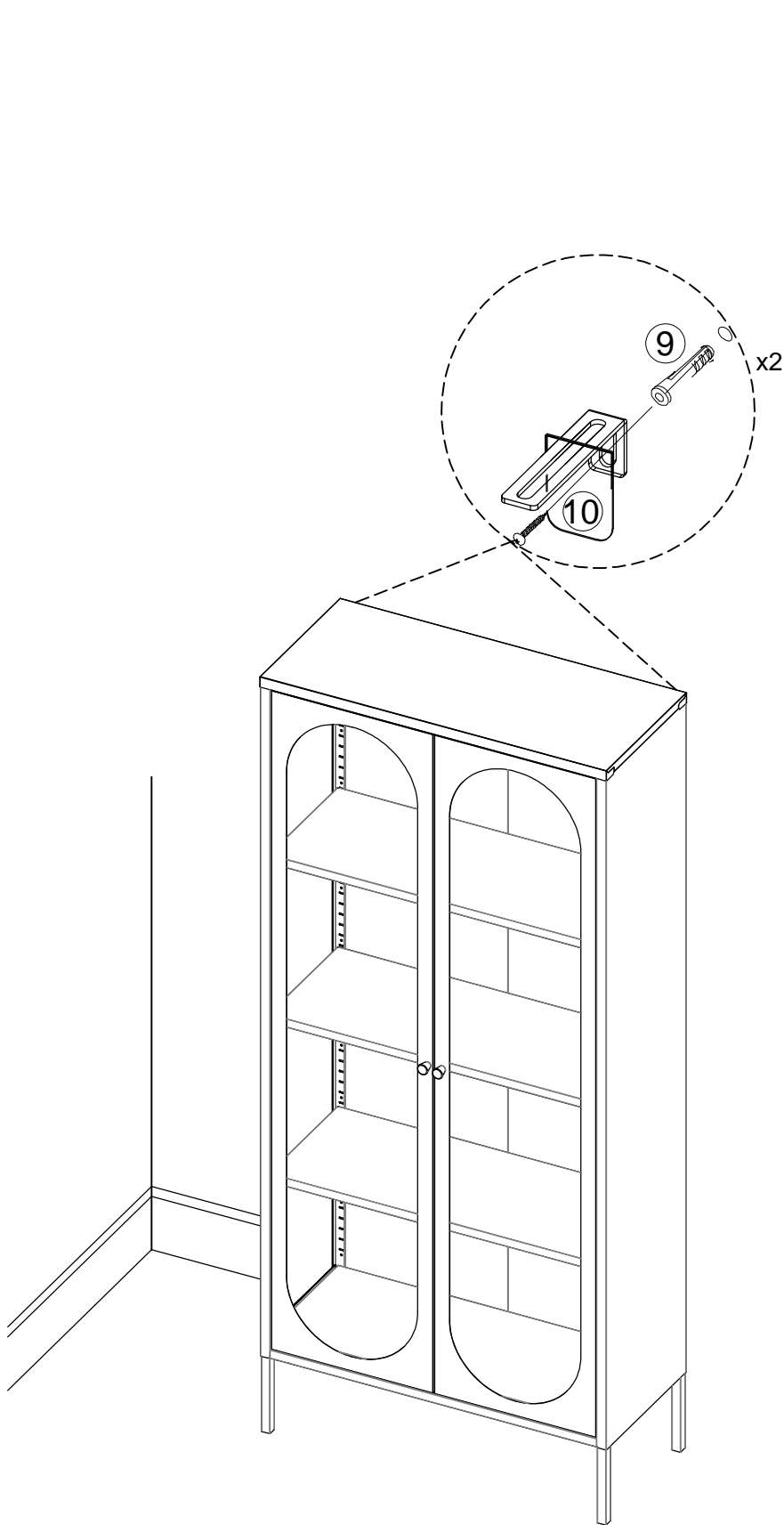

Gaps may appear between the top of the doors and the frame if the item is not on level ground; use the plastic foot cover to level.