

30'

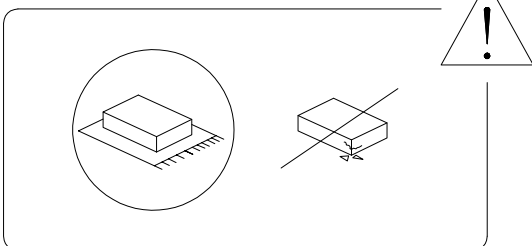

2

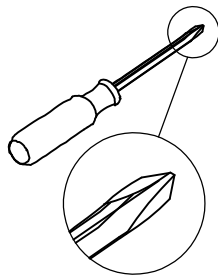
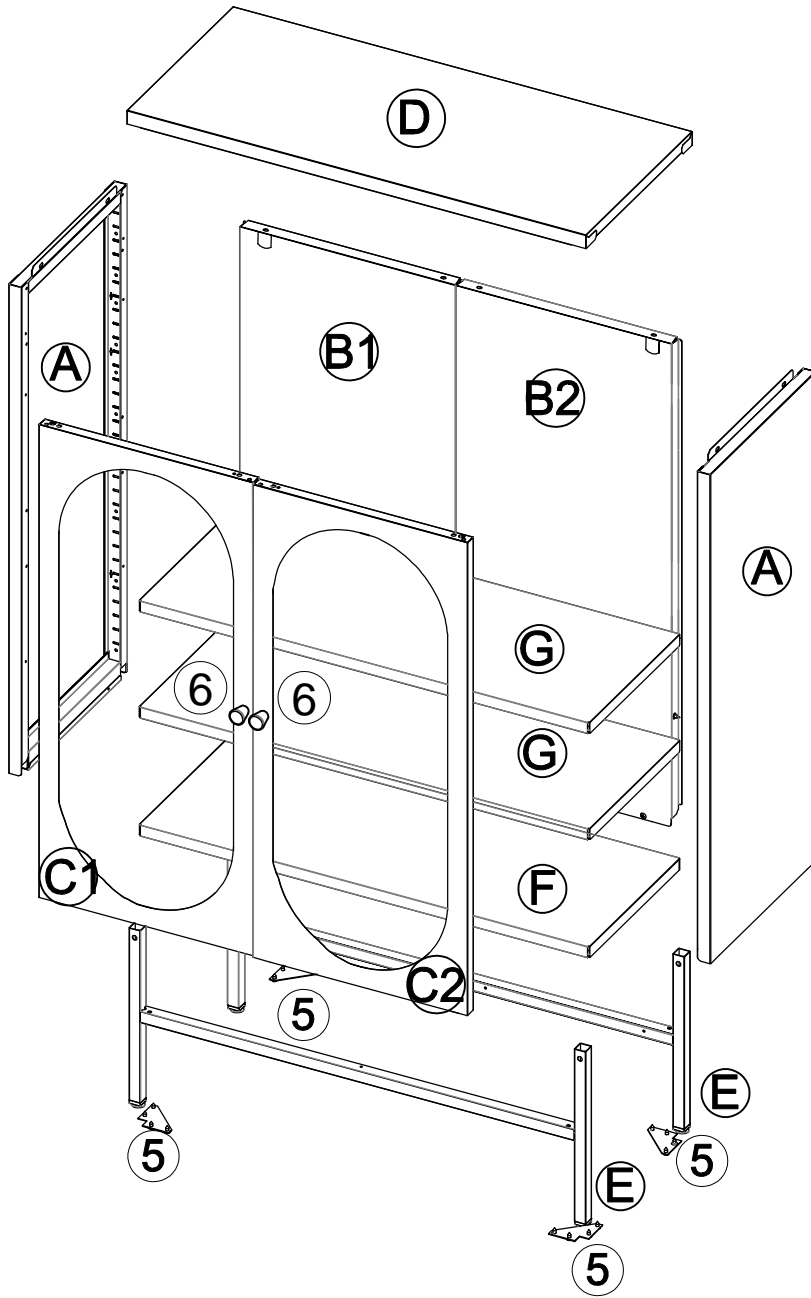

Hardware	Ctn No.	1
----------	---------	---

No.	Size	Qty
A	918x400x24mm	2
B1	889.5x380x23mm	1
B2	889.5x384x23mm	1
C1	871x373.5x20mm	1
C2	871x373.5x20mm	1
D	801x402x38mm	1
E	320x797x20mm	2
F	796x351x25mm	1
G	796x350x20mm	2

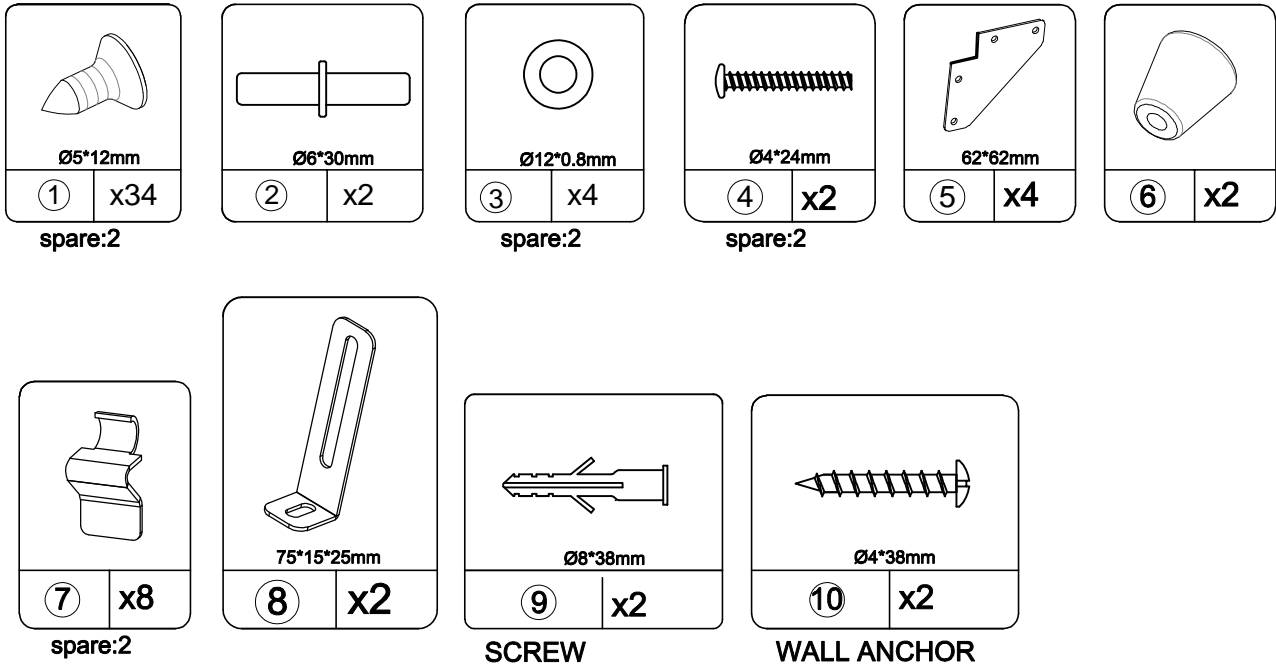

(1) - Attach (A) to (E) as below shown.

Make sure the holes are nearest to outside otherwise will affect door assembling.

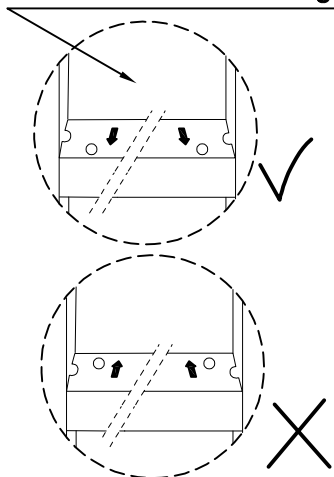

The plastic foot cover face down

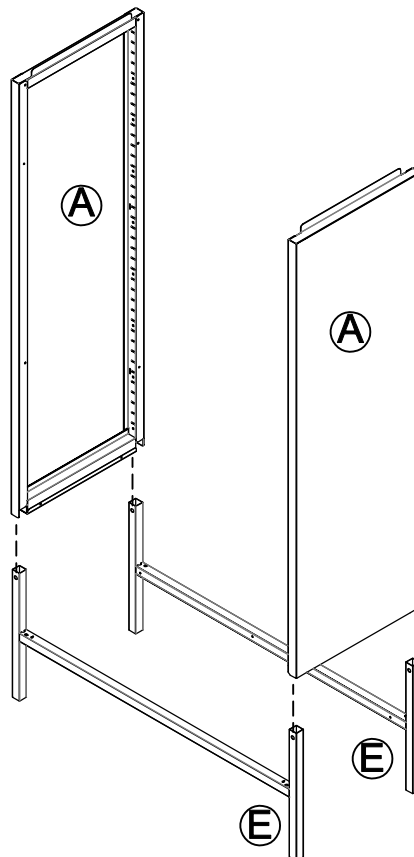

(2) - Attach ⑤ to (A)&(E) as below shown.

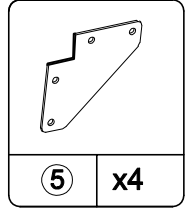
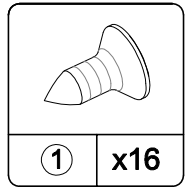
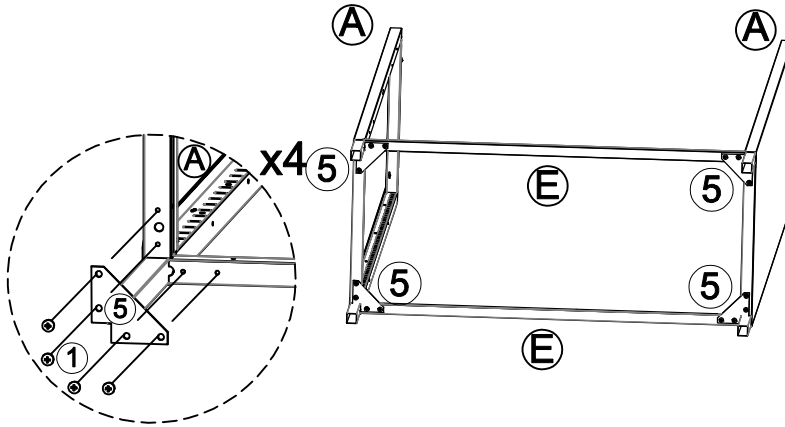

(3) - Attach (B) to (A) & (E) as below shown.

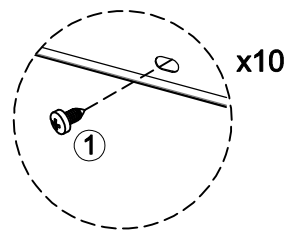
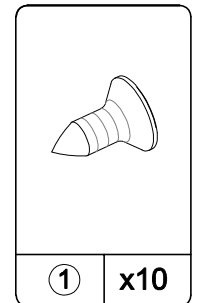
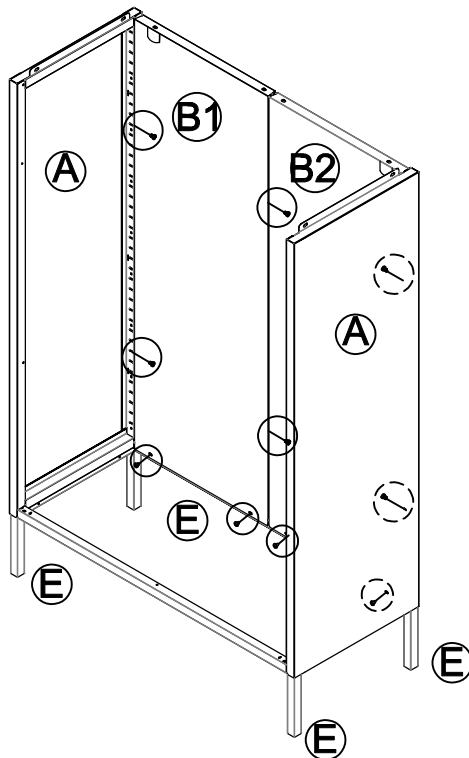

(4) - Attach (F) to (A) & (B) & (E) as below shown.

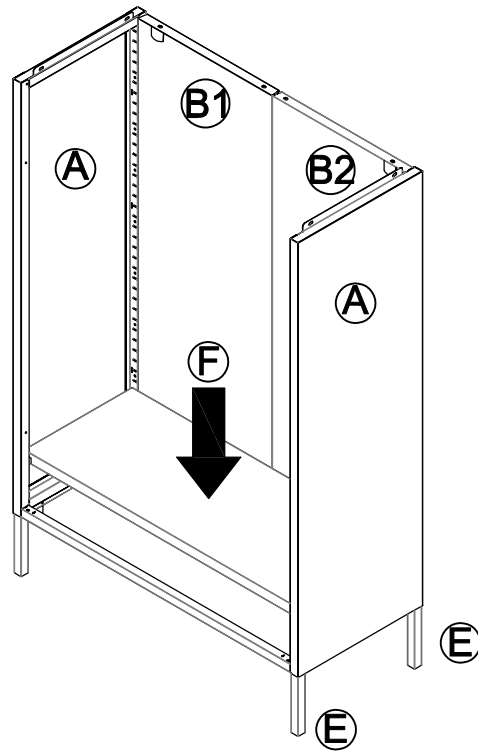

(5) - Attach (D) to (A) & (B) as below shown.

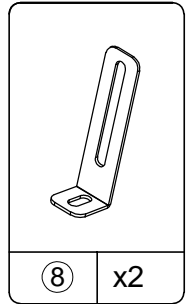
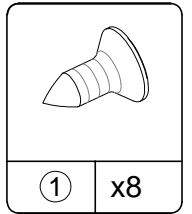
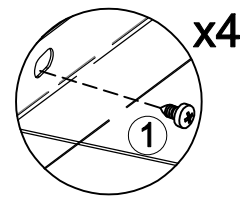
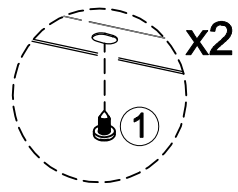
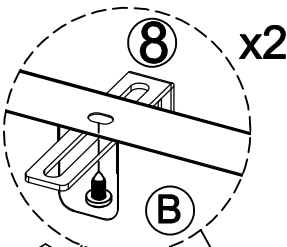
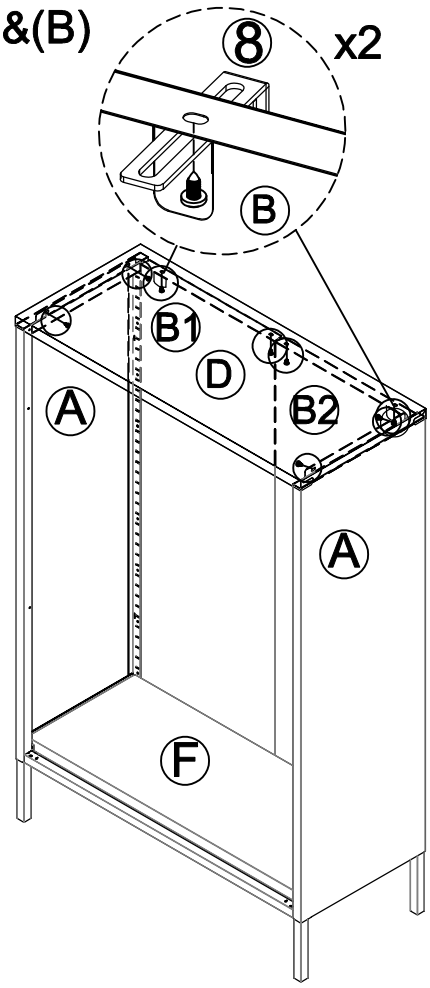

(6) - Attach (G) to pre-assembled unit as below shown.

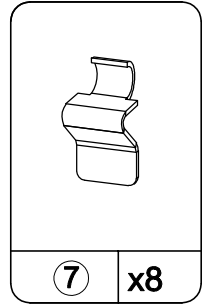
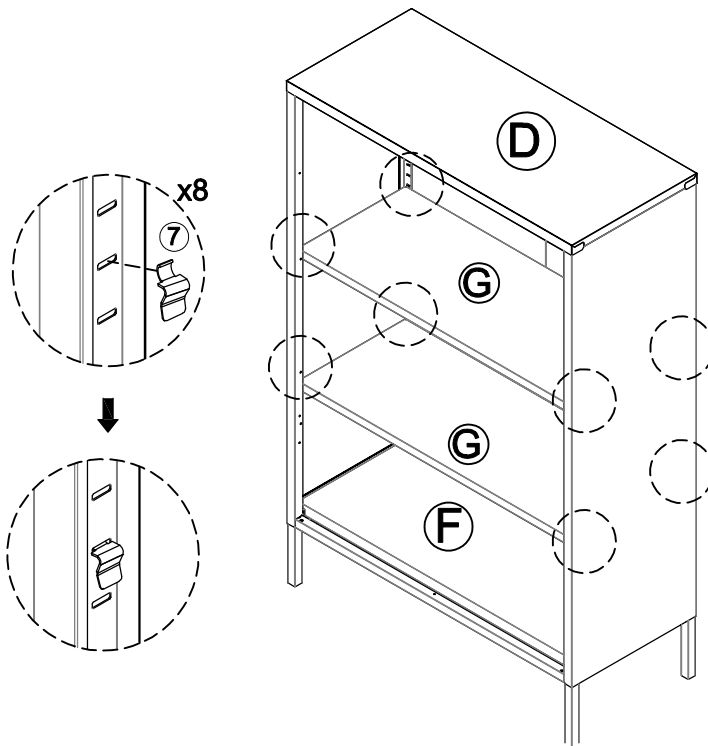

(7) - Attach (6) to (C) as below shown.

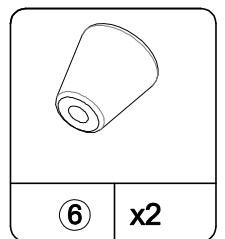
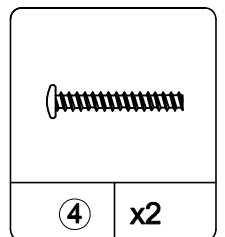
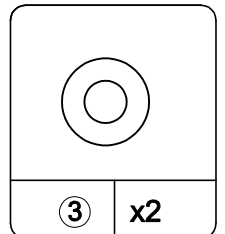
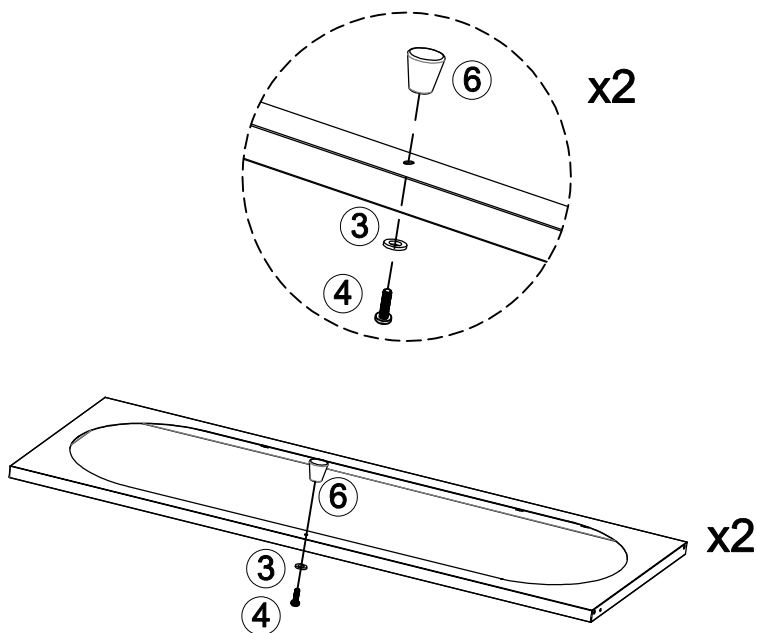

(8) - Attach (2) & (3) to pre-assembled unit as below shown.

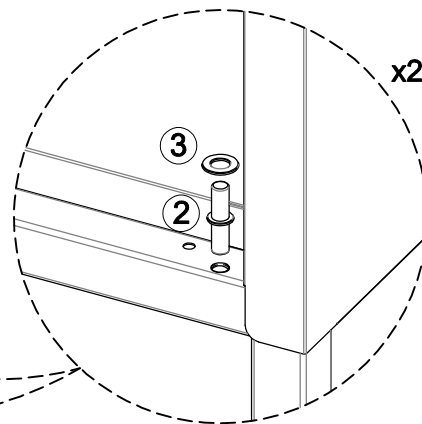
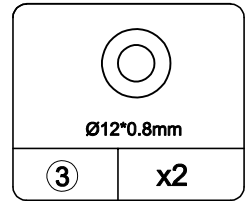
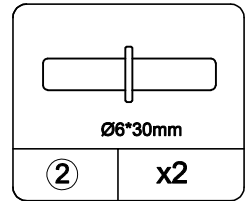
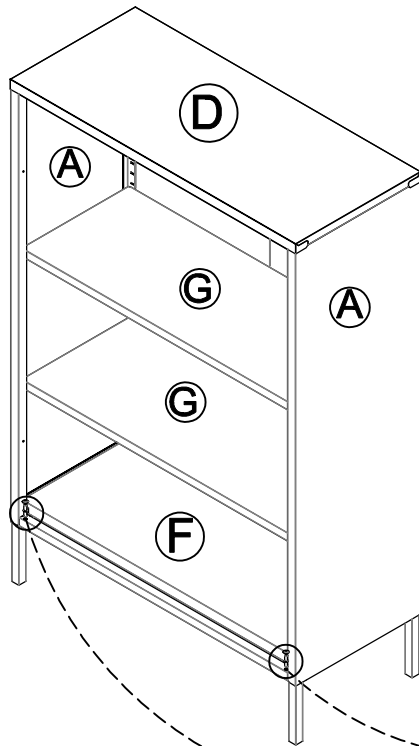

(9) - Attach (C) to pre-assembled unit as below shown.

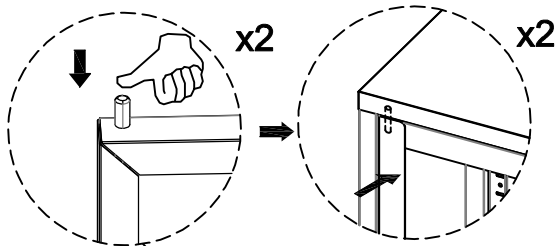

Make sure to use the hole which is nearest to side panel for inserting pin(2) otherwise will affect door assembling.

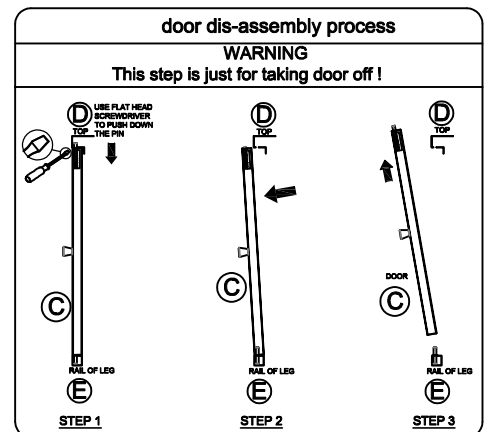
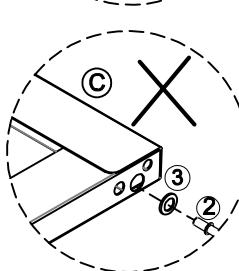
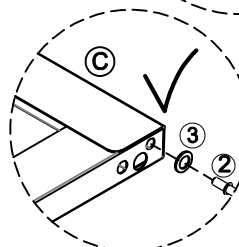
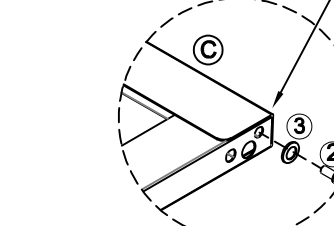
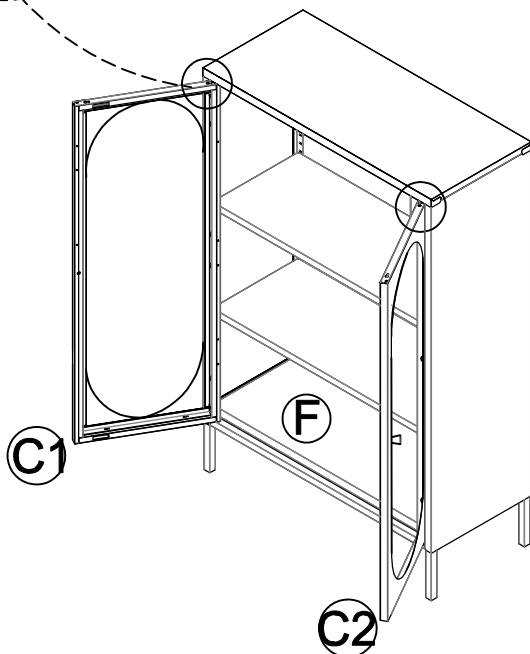
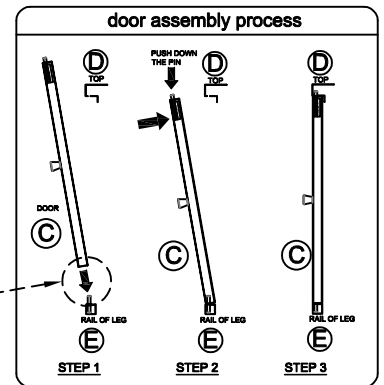

(10)

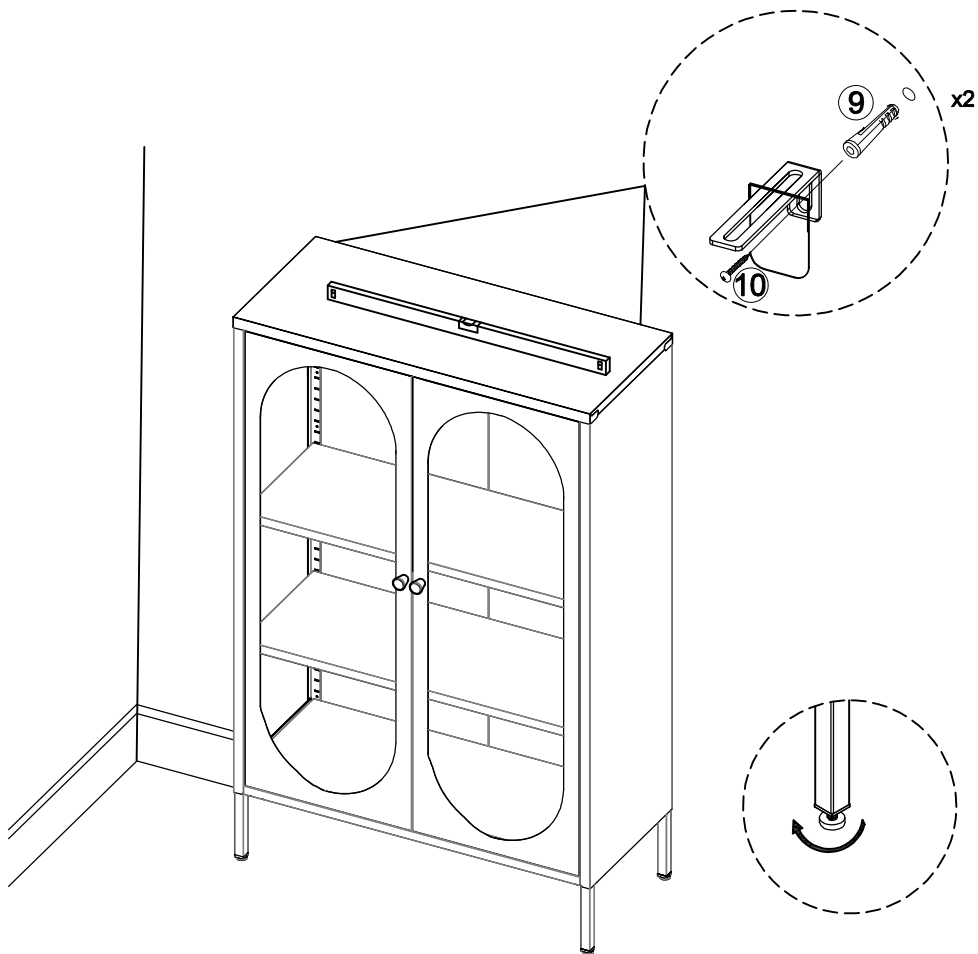
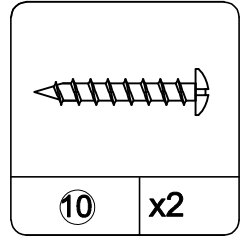
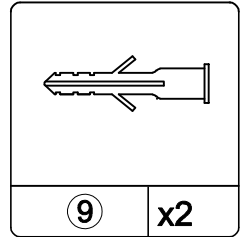

Gaps may appear between the top of the doors and the frame if the item is not on level ground; use the plastic foot cover to level.