

ITEM NO:

Assembly instruction

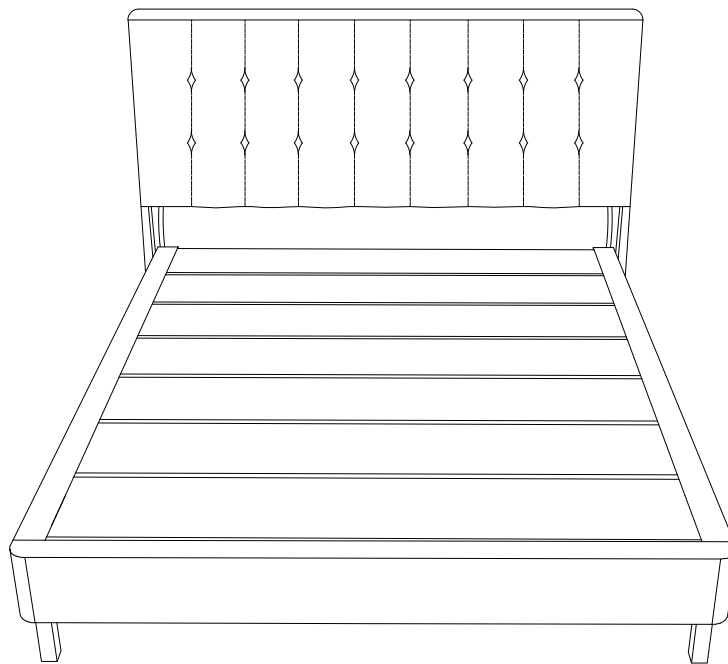

A

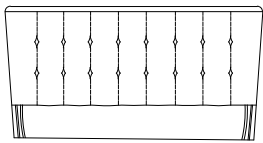

Headbord 1 pc

B

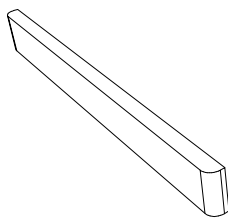

Bed tailgate 1 pc

C

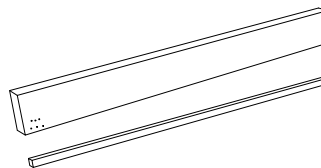

Left bed side panel 1 pc

D

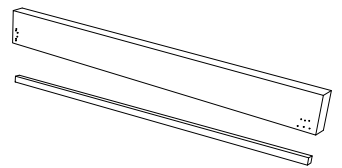

Right bed side panel 1 pc

E

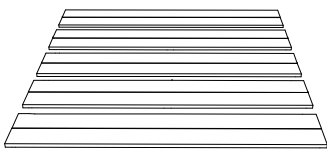

Sticks 1 pc

F

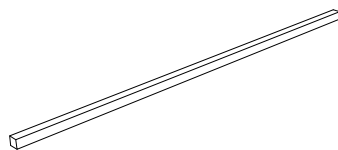

Metal cross brace 2 pc

G

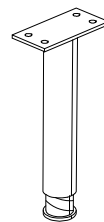

Middle leg 6 pcs

H

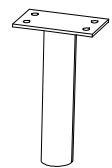

leg 2 pcs

I

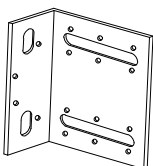

2 pcs

J



2 pcs

K

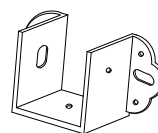

2 pcs

①

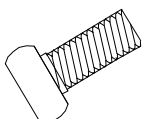

20 pcs

②

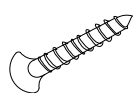

White / Long
56 pcs

③

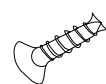

Black / Short
50 pcs

STEP 1

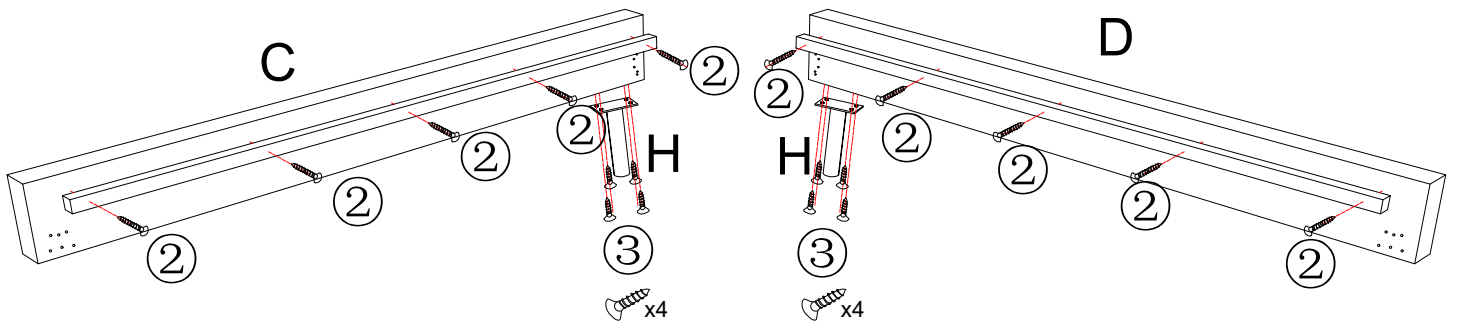

STEP 2

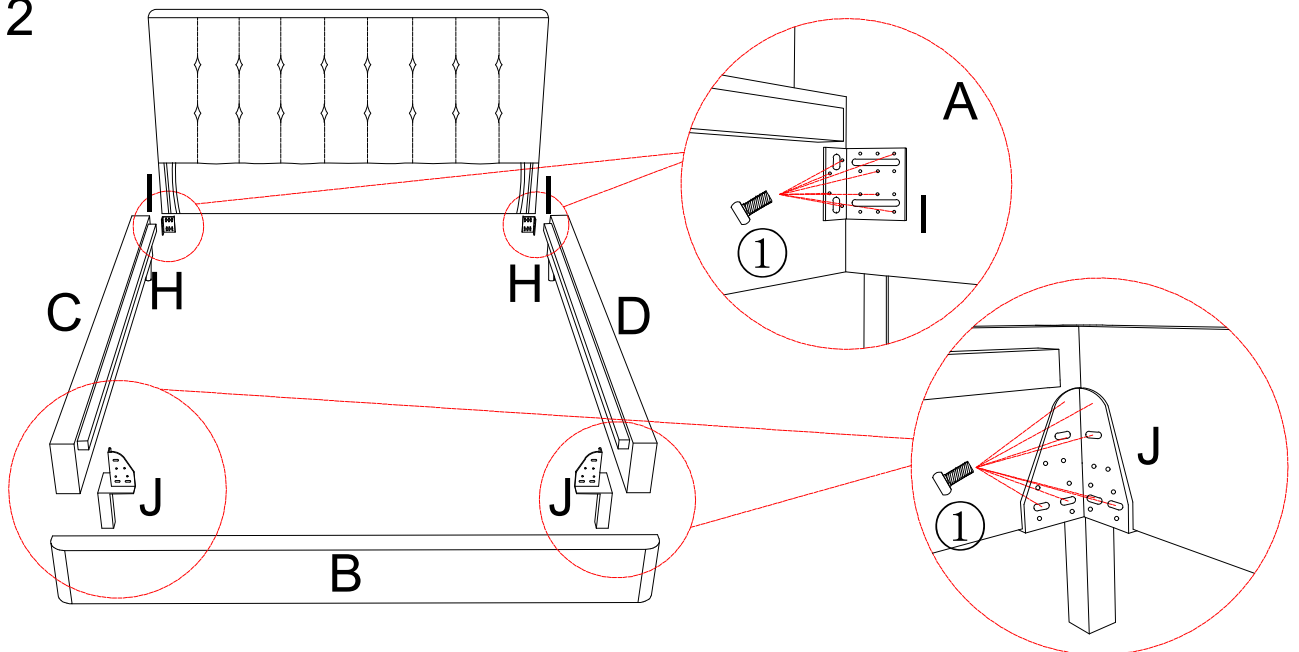

STEP 3

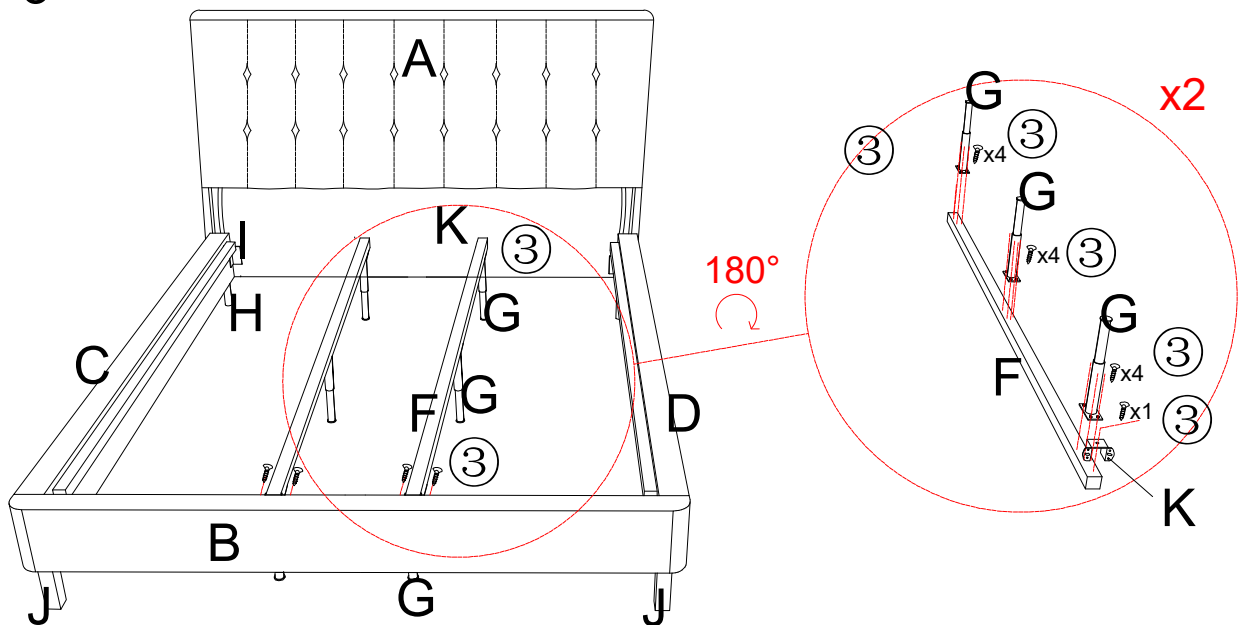

STEP 4

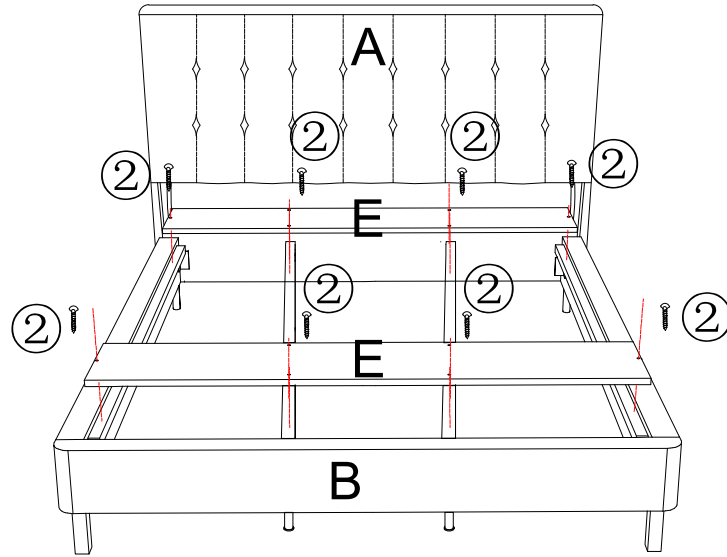

STEP 5

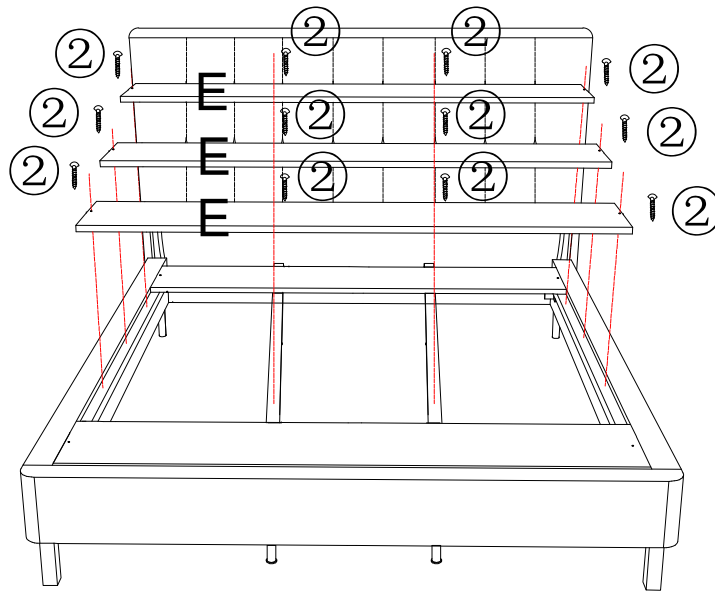

STEP 6

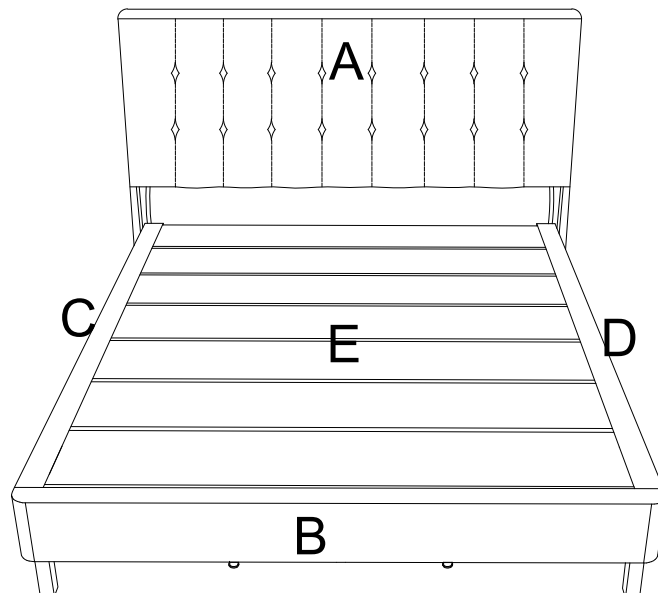



The headboard connectors should be installed horizontally at the headboard position and vertically at the bedside position. Do not tighten the screws yet; secure them only after placing the bed slats.



Before tightening the screws on the small wooden strip attached to the bed frame, position the strip slightly below the top edge of the frame. Place the bed slats on the strip and check the height to ensure they align flush with the frame once installed. Then secure the strip by tightening the screws.



After the slats have been adjusted to the correct height, secure the connectors at the footboard position.

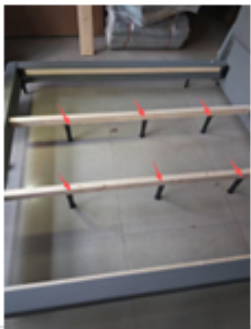

The support legs should be spaced approximately 20 centimeters apart and evenly secured to the joists. The height of the support joists should align with the height of the small wooden slats on the bed frame.



The support leg closest to the headboard should be positioned approximately 30 centimeters away from the headboard.



After several bed slats have been installed, tighten the screws at the footboard to avoid improper width alignment.