

ASSEMBLY INSTRUCTION

PART LIST

A*16pcs



M6*15MM

B*4pcs



M6*18MM

C*4pcs



M6*35MM

D*5pcs



18*40MM

E*1pcs



M4

F*2pcs



100*60MM

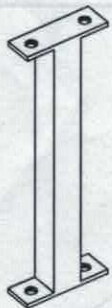
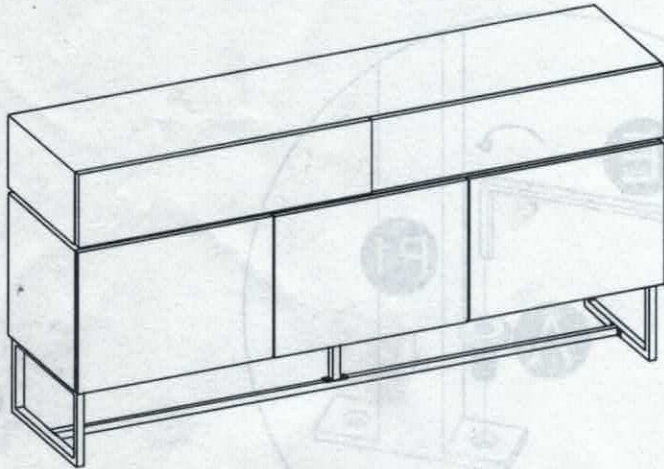

P1x1pc

P2x1pc

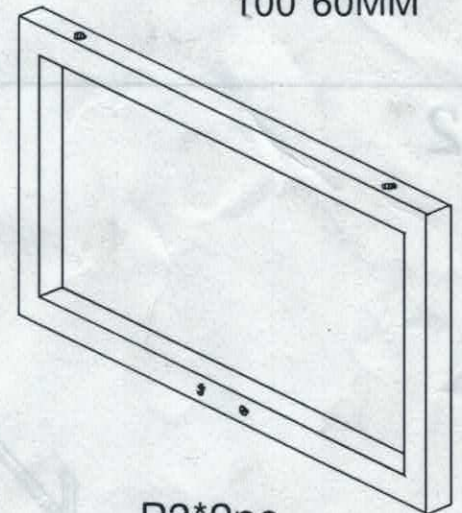
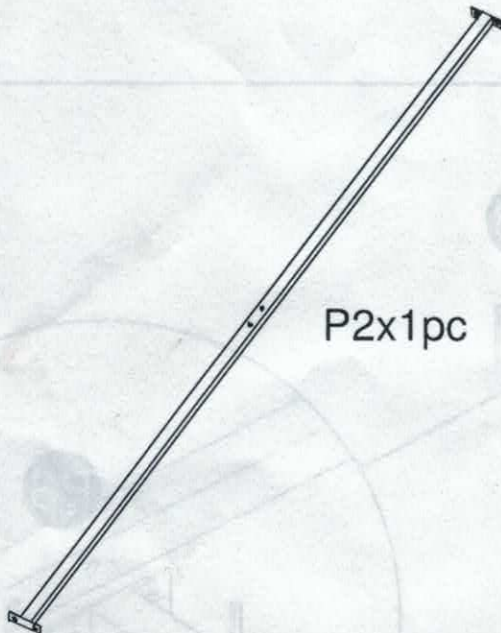

P3*2pc

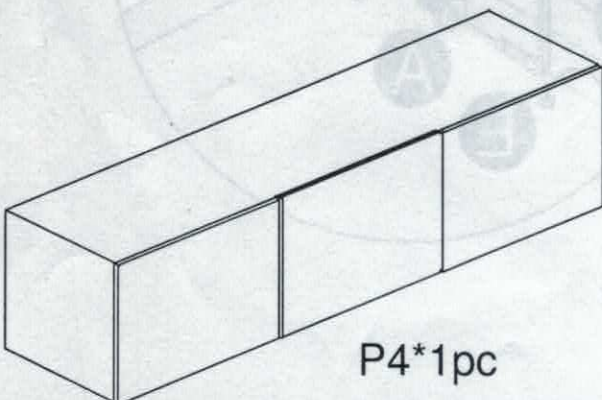

P4*1pc

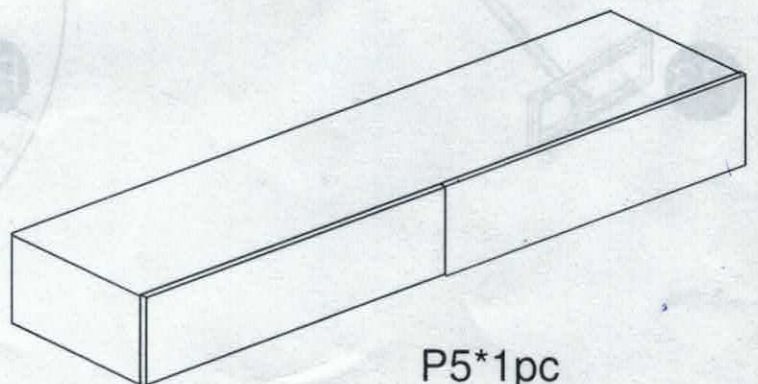

P5*1pc

ASSEMBLY INSTRUCTION

1

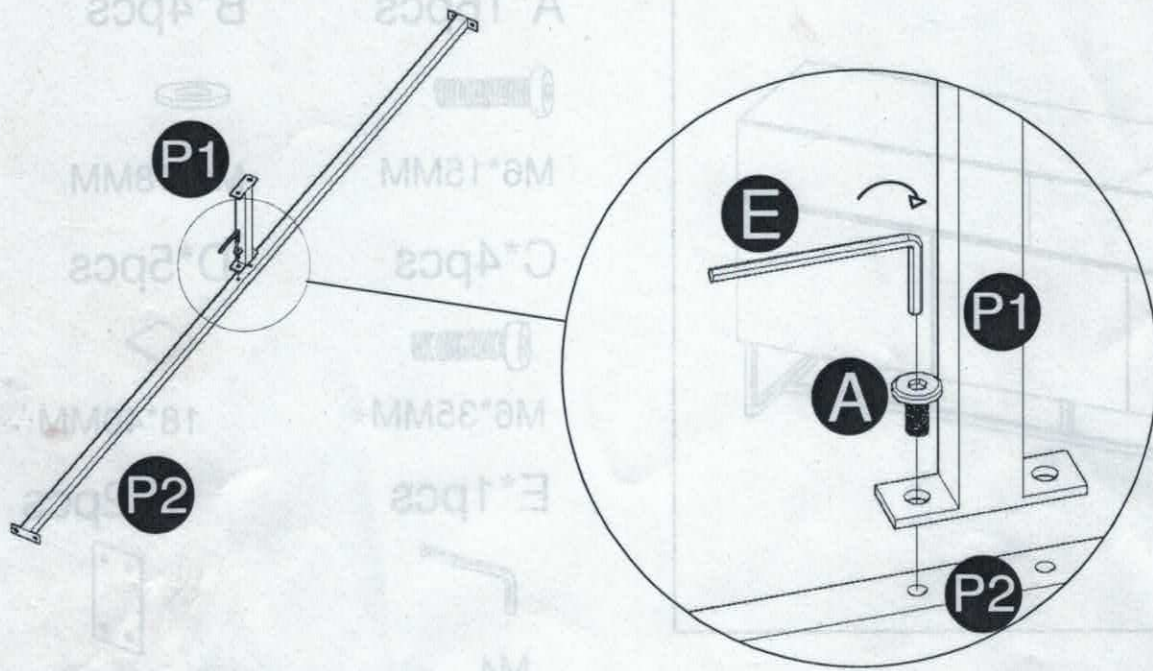

2

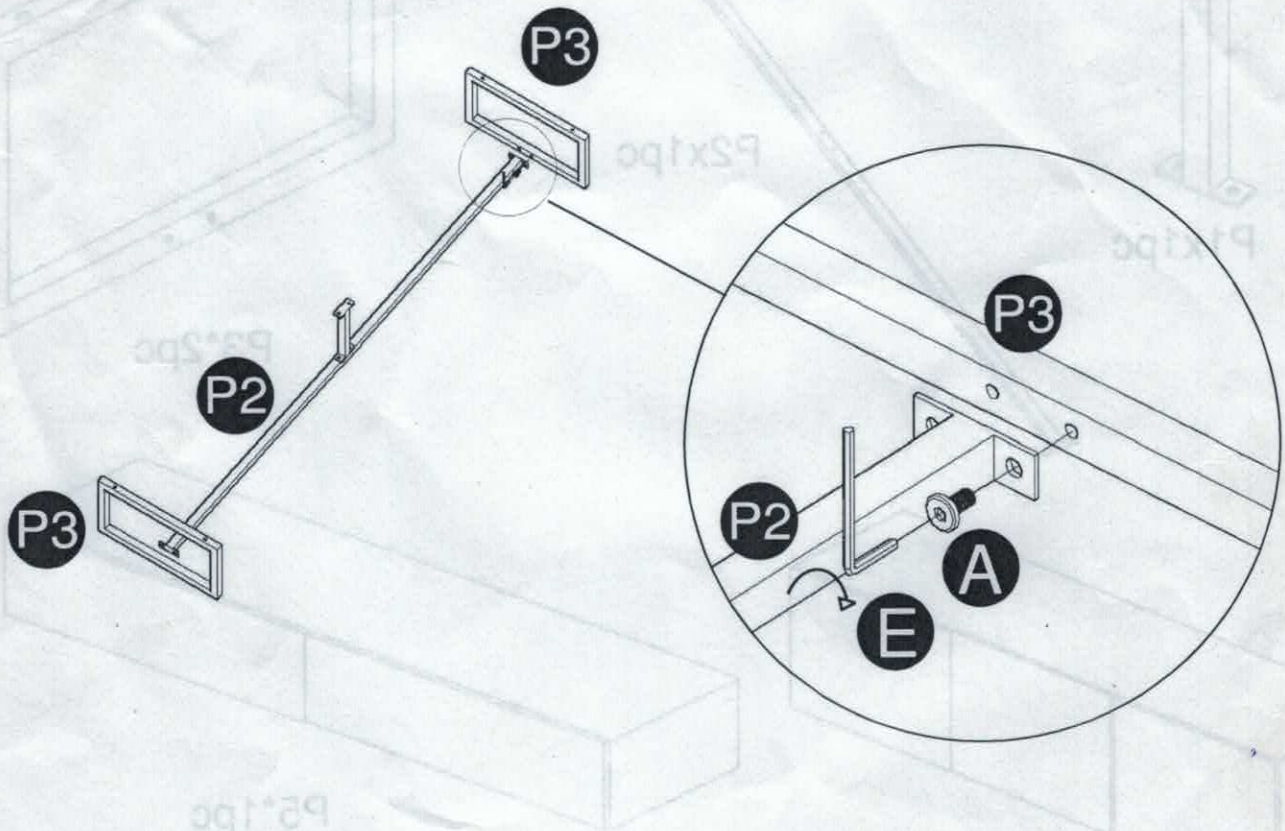

ASSEMBLY INSTRUCTION

3

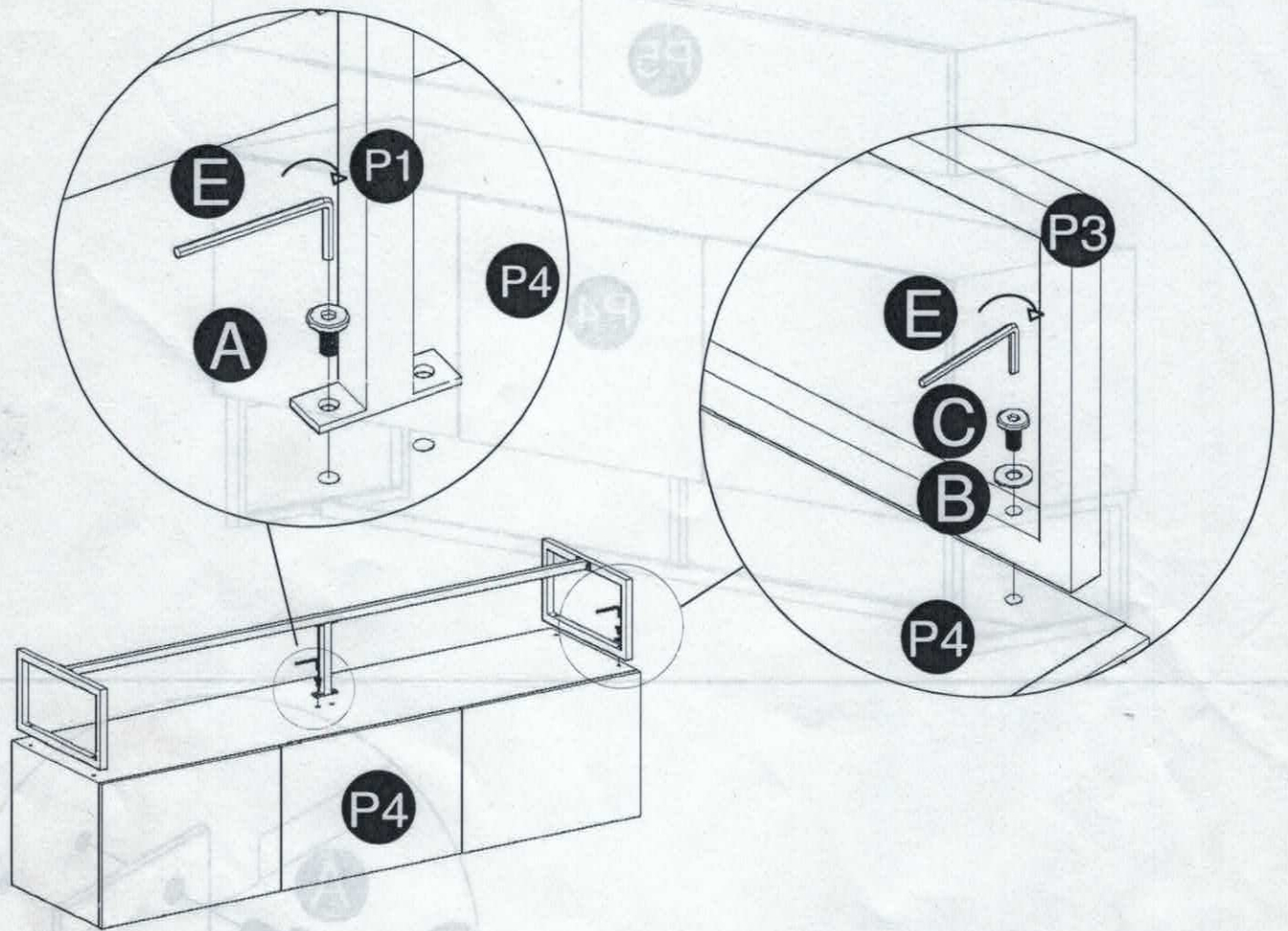

4

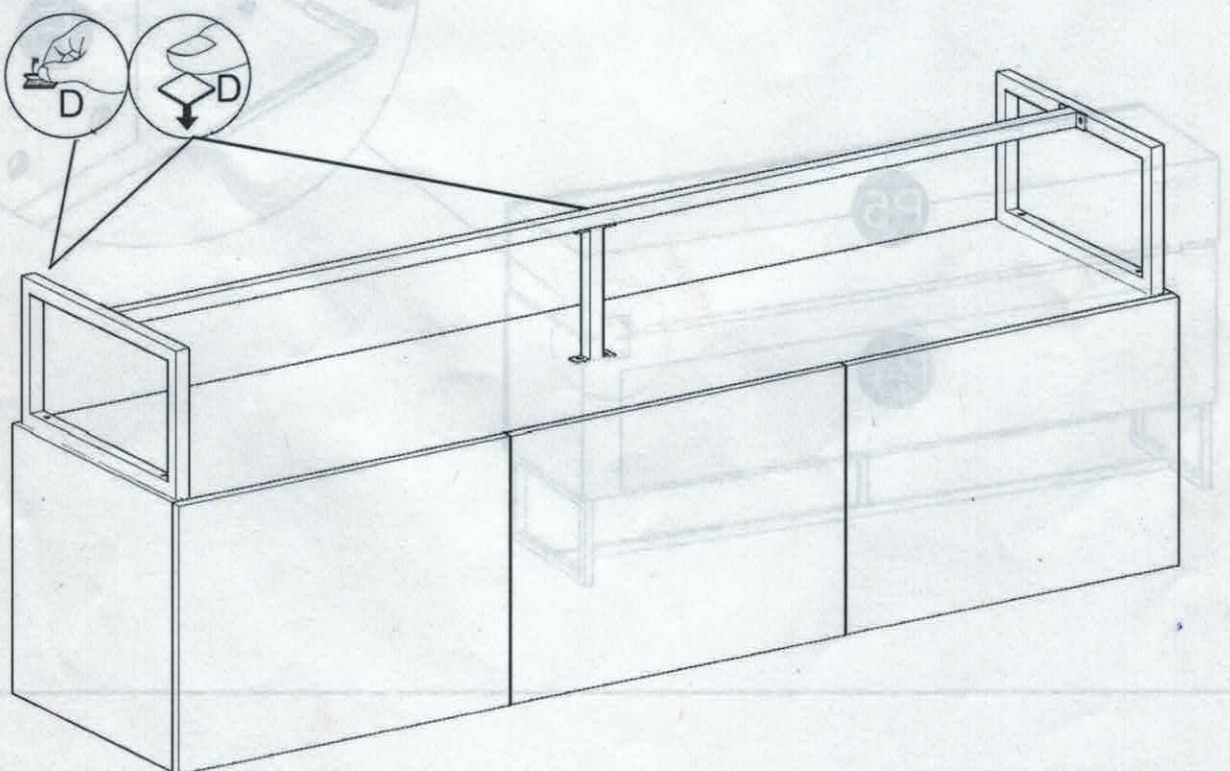

5

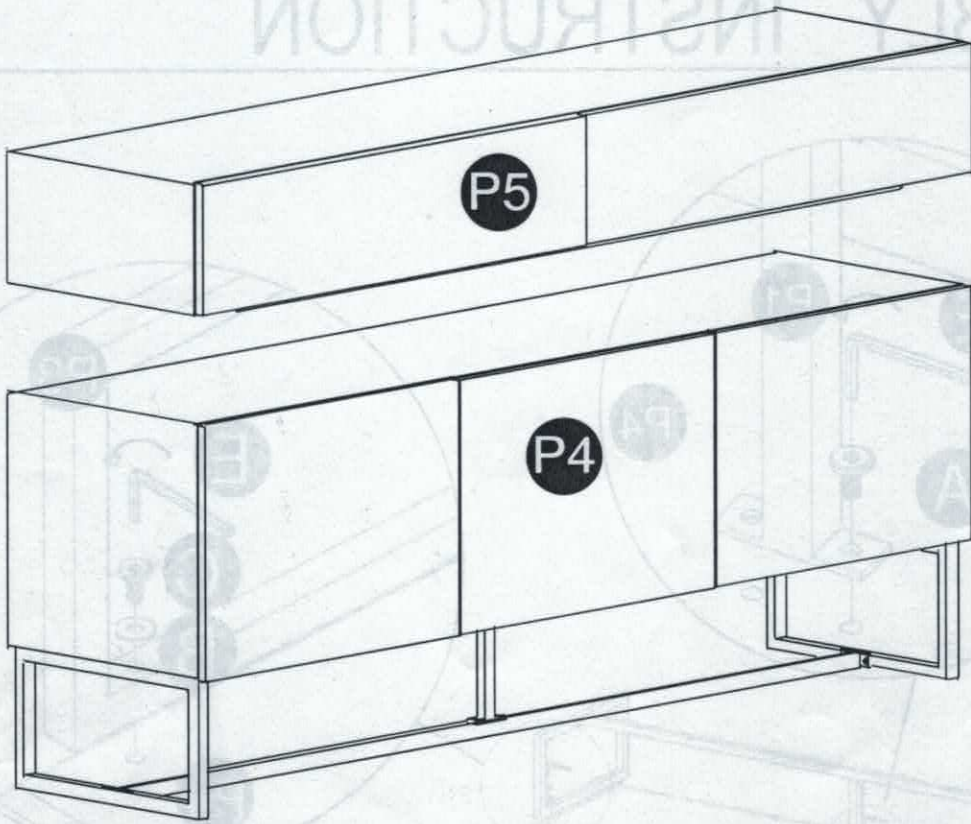

6

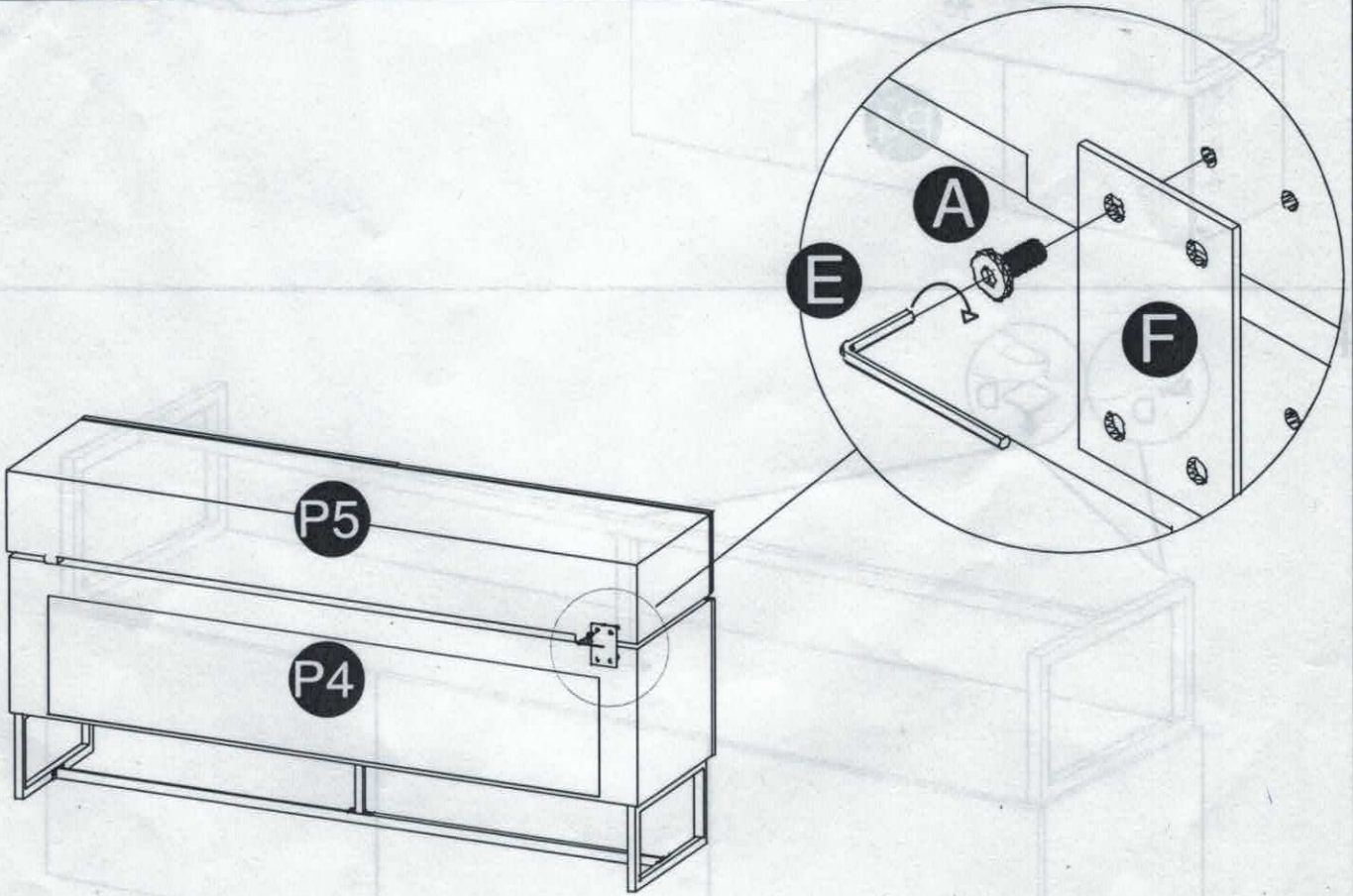

Finish:

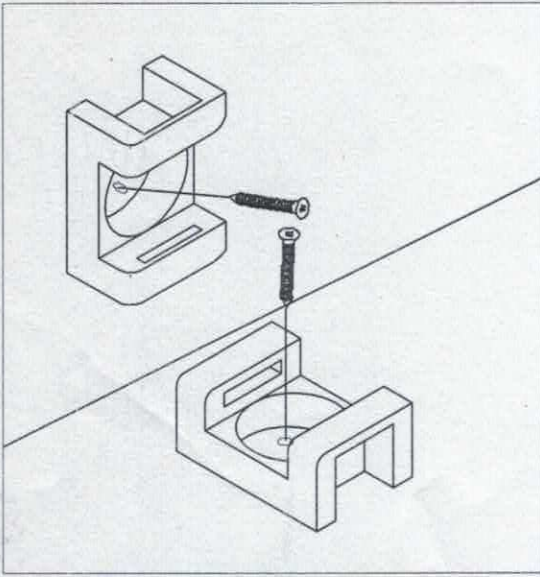

STEP 1

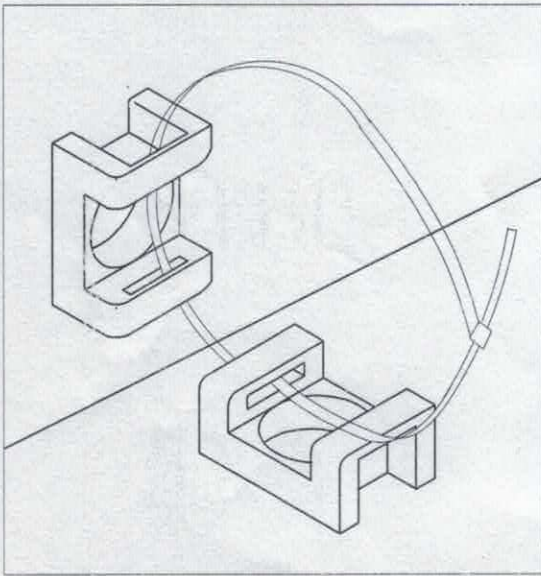

STEP 2

Assembling done.
Anti-tipping hardware
is provided and should
be used !